

PRACTICE PAPERS 2020

www.mtg.in | June 2020 | Pages 80 | ₹ 40

NEET | **JEE** | **BITSAT**

ADVANCED

GEAR UP FOR
JEE MAIN

CHEMISTRY

India's #1
CHEMISTRY MONTHLY FOR
JEE (Main & Advanced) & NEET

 **today**

Get Set Go for

NEET | JEE

**NCERT
CORNER**

**CONCEPT
MAP**

mtg

Trust of more than
1 Crore Readers
Since 1982



2019010012556

**MONTHLY
TEST DRIVE**

CLASS XI-XII

mtg

Success Made Simple

IF YOU AIM TO BE #1, BE WITH THE #1.

(IT'S THAT SIMPLE!)

#1 BESTSELLER ON AMAZON

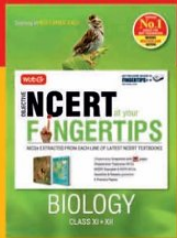

AMONG TOP 10 AMAZON BESTSELLERS

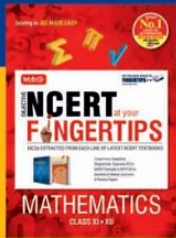
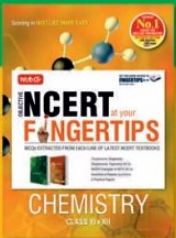
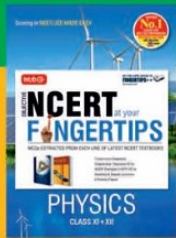
**WHAT MAKES US #1:**

- Chapterwise student-friendly synopses for quick-and-easy revision
- Topicwise MCQs to check your progress
- NCERT Exemplar MCQs
- Assertion & Reason questions for an edge in your competitive exams Preparation
- HOTS MCQs to boost your concepts
- 6 Practice Papers for self-assessment
- High Definition (HD) multicolour pages

Call 0124-6601200/1800-10-38 673 or email info@mtg.in to learn more

CHEMISTRY today

Volume 29

No. 6

June 2020

Managing Editor
Mahabir Singh
Editor
Anil Ahlawat

Corporate Office:

Plot 99, Sector 44 Institutional area, Gurugram -122 003 (HR).
Tel : 0124-6601200 e-mail : info@mtg.in website : www.mtg.in

Regd. Office:

406, Taj Apartment, Near Safdarjung Hospital, New Delhi - 110029.

CONTENTS

Competition Edge

Get Set Go for NEET	5
NEET Practice Paper 2020	8
Get Set Go for JEE	16
Gear Up for JEE Main 2020	20
JEE Advanced Practice Paper 2020	26
Concept Map	35
BITSAT Practice Paper 2020	37
Monthly Test Drive XI	45
Learn Fast	48
Monthly Test Drive XII	58
NCERT Corner	62
Exam Prep	69
You Ask, We Answer	77

Subscribe online at www.mtg.in

	Individual Subscription Rates			Combined Subscription Rates			
	9 months	15 months	27 months	9 months	15 months	27 months	
Mathematics Today	300	500	850	PCM	900	1400	2500
Chemistry Today	300	500	850	PCB	900	1400	2500
Physics For You	300	500	850	PCMB	1200	1900	3400
Biology Today	300	500	850				

Send D.D./D.O in favour of MTG Learning Media (P) Ltd.

Payments should be made directly to : MTG Learning Media (P) Ltd.

Plot No. 99, Sector 44, Gurugram - 122003 (Haryana)

We have not appointed any subscription agent.

Printed and Published by Mahabir Singh on behalf of MTG Learning Media Pvt. Ltd. Printed at HT Media Ltd., B-2, Sector-63, Noida, UP-201307 and published at 406, Taj Apartment, Ring Road, Near Safdarjung Hospital, New Delhi - 110029.

Editor : Anil Ahlawat

Readers are advised to make appropriate thorough enquiries before acting upon any advertisements published in this magazine. Focus/Infocus features are marketing incentives. MTG does not vouch or subscribe to the claims and representations made by advertisers. All disputes are subject to Delhi jurisdiction only. Copyright © MTG Learning Media (P) Ltd.

All rights reserved. Reproduction in any form is prohibited.

Reach the peak of readiness for JEE Main July 2020

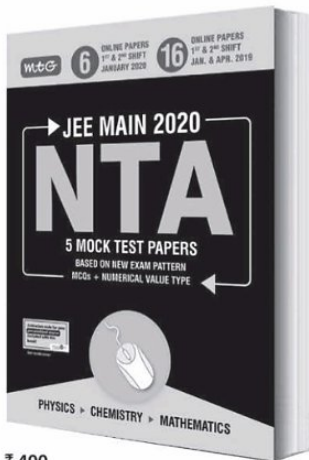

₹ 400

Highlights

- Fully Solved Authentic Papers
- 6 (Jan, 2020) + 16 (Jan. & Apr., 2019) Online Papers
- 2,325 MCQs for Practice
- Chapterwise Tabular and Graphical Analysis Showing the Weightage of Chapters
- 5 MTPs as per the latest JEE Main pattern

Practice Online Tests to Predict Your Rank

WITH JANUARY 2020 ONLINE PAPERS

The Wait is Over! MTG Presents you all the 6 Fully Solved Question Papers of **JEE Main (I) January, 2020** & 16 Fully Solved Question Papers of **JEE Main (I) January** and **JEE Main (II) April, 2019** conducted by NTA with Chapterwise graphical analysis showing the weightage of chapters and Mock Test Papers as per latest pattern of JEE Main. Get the maximum benefit from the book through personalised course on **Pedagogy app**. The best preparation for tomorrow is doing your best today so, go and get your copy.

Make It Happen,
CRACK JEE Main

Get the complete feel of Online exam
by attempting tests on computers

Take the Final Leap Towards **JEE Main** Success!

Available at all leading book shops throughout the country. To buy online visit www.mtg.in.
For more information or for help in placing your order, call 0124-6601200 or email: info@mtg.in

GET SET GO

NEET



with exclusive and brain storming MCQs

Practicing these MCQs help to strengthen your concepts and give you extra edge in your NEET preparation

- A is a binary compound of a univalent metal. 1.422 g of A reacts completely with 0.321 g of sulphur in an evacuated and sealed tube to give 1.743 g of a white crystalline solid (B) that formed a hydrated double salt (C) with $\text{Al}_2(\text{SO}_4)_3$. A and B are respectively

(a) KO_2 , K_2SO_4 (b) NaO_2 , Na_2SO_4
 (c) K_2O , K_2SO_4 (d) Na_2O , Na_2SO_4
- IUPAC name of the following compound is

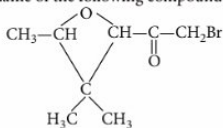

- (a) 1-bromo-3, 5-epoxy-4, 4-dimethyl-2-hexanone
 (b) 1-bromo-3, 3-dimethyl-2-oxo-2-hexanone
 (c) 1-bromo-3, 3-dimethyl acetone
 (d) 1-bromo-4, 4-dimethyl-5-oxo-hexanone.
- For the equilibrium, $2\text{SO}_3(\text{g}) \rightleftharpoons 2\text{SO}_2(\text{g}) + \text{O}_2(\text{g})$, the partial pressures of SO_3 , SO_2 and O_2 gases at 650 K are respectively 0.3 bar, 0.6 bar and 0.4 bar. If the moles of both the oxides of sulphur are so adjusted as equal, what will be the partial pressure of O_2 ?

(a) 0.4 (b) 1.0 (c) 1.3 (d) 1.6
 - Which of the following is the product for the given reaction?

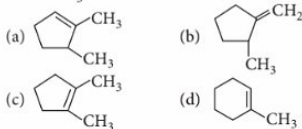

- Amphoteric oxide (X) + $3\text{C} + \text{Cl}_2 \longrightarrow$ Poisonous gas + anhydrous chloride (Y)

Hydrated chloride $\xrightarrow{\Delta} \text{Z}$

Element present in (Y) other than 'Cl' reacts with concentrated HCl but leads to passivation with conc. HNO_3 . Select the correct option.

(a) $X = Z$ and Y on reacting with LiH forms strong oxidising agent.
 (b) $X = Z$ and Y on reacting with LiH forms strong reducing agent.
 (c) $X \neq Z$ and Y is used as a catalyst in Friedel-Crafts reaction.
 (d) $X \neq Z$ and Y on reacting with LiH forms strong oxidising agent.
- $\text{N}_2 + 3\text{H}_2 \longrightarrow 2\text{NH}_3$

Molecular weights of NH_3 and N_2 are x_1 and x_2 , their equivalent weights are y_1 and y_2 respectively. Then $(y_1 - y_2)$ is

- (a) $\left(\frac{2x_1 - x_2}{6}\right)$ (b) $(x_1 - x_2)$
 (c) $(3x_1 - x_2)$ (d) $(x_1 - 3x_2)$

7. By what method the quantity of organic pollutants in water can be determined?
 (a) By measuring BOD
 (b) By pH measurement
 (c) By transparency measurement
 (d) By measuring the change of colour
8. From the observations given below, suggest the relation between X, Y and Z.

Experiment	Heat supplied	Work done	ΔE
I	100 J supplied to the system	200 J work done by the system	X Joules
II	200 J supplied to the system	200 J work done on the system	Y Joules
III	400 J lost to the system	100 J work done by the system	Z Joules

- (a) $X = Y = Z$ (b) $Y > X > Z$
 (c) $Y > Z > X$ (d) $X > Z > Y$

9. $C_3H_8(g) + A \rightarrow \text{syn gas} \xrightarrow{Fe_2O_3/Cr_2O_3} X$
 $Y + Z \xrightarrow[\text{High } P]{\text{Cold water}} Z(g) + \text{a soln. of } Y.$

Z has low chemical reactivity at room temperature but under vigorous suitable conditions it reacts with other elements to form very useful compounds.

Z is also being looked upon as prospective source of energy for future. Which two substances are same ?

- (a) X and Z (b) A and X
 (c) A and Y (d) A and Z
10. Which of the following statements is incorrect?
 (a) Among O_2^+ , O_2 and O_2^- the stability decreases as $O_2^+ > O_2 > O_2^-$.
 (b) He_2 molecule does not exist as the effect of bonding and anti-bonding molecular orbitals cancel each other.
 (c) C_2 , O_2^{2-} and Li_2 are diamagnetic.
 (d) In F_2 molecule, the energy of $\sigma 2p_z$ is more than π_{2px} and π_{2py} .

11. A gas column is trapped between closed end of a tube and a mercury column of length (h) when this tube is placed with its open end upwards the length of gas column is (ℓ_1), the length of gas column becomes (ℓ_2) when open end of tube is held downwards. Find atmospheric pressure in terms of height of Hg column.

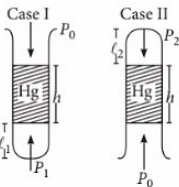

- (a) $\frac{h(\ell_1 - \ell_2)}{(\ell_1 + \ell_2)}$ (b) $\frac{h(\ell_1 + \ell_2)}{\ell_2 - \ell_1}$
 (c) $h \left(\frac{(\ell_1 \times \ell_2)}{\ell_2 - \ell_1} \right)$ (d) None of these

12. For the element X, student Riya measured its radius as 102 nm, student Rajat as 203 nm, and Aman as 100 nm, using same apparatus. Their teacher explained that measurements were correct by saying that recorded values by three students were
 (a) crystal, van der Waal and covalent radii
 (b) covalent, crystal and van der Waal radii
 (c) van der Waal, ionic and covalent radii
 (d) none is correct.
13. The molar composition of polluted air is as follows :

Gas	At. wt.	Mole percentage
Oxygen	16	16%
Nitrogen	14	80%
Carbon dioxide	—	03%
Sulphur dioxide	—	01%

What is the average molecular weight of the given polluted air? (Given, atomic weights of C and S are 12 and 32 respectively.)

- (a) 28.51 (b) 50.08 (c) 29.48 (d) 45.12
14. 0.395 g of an organic compound by Carius method for the estimation of sulphur gave 0.582 g of $BaSO_4$. The percentage of sulphur in the compound is
 (a) 20.24 (b) 35 (c) 40 (d) 45
15. An electron in a hydrogen like atom makes transition from a state in which its de-Broglie wavelength is λ_1 to a state where its de-Broglie wavelength is λ_2 then wavelength of photon (λ) generated will be

$$(a) \lambda = \lambda_1 - \lambda_2 \quad (b) \lambda = \frac{4mc}{h} \left\{ \frac{\lambda_1^2 \lambda_2^2}{\lambda_1^2 - \lambda_2^2} \right\}$$

$$(c) \lambda = \sqrt{\frac{\lambda_1^2 \lambda_2^2}{\lambda_1^2 - \lambda_2^2}} \quad (d) \lambda = \frac{2mc}{h} \left\{ \frac{\lambda_1^2 \lambda_2^2}{\lambda_1^2 - \lambda_2^2} \right\}$$

SOLUTIONS

1. (a) : B forms double salt with $\text{Al}_2(\text{SO}_4)_3$ and thus, may be $\text{K}_2\text{SO}_4 \cdot (\text{A}) + \text{S} \longrightarrow (\text{B}) \text{K}_2\text{SO}_4$
 $\therefore 1.743 \text{ g K}_2\text{SO}_4$ is obtained by 1.422 g of A

$$\therefore 174 \text{ g K}_2\text{SO}_4 \text{ is obtained by } \frac{1.422 \times 174}{1.743} = 142 \text{ g of A}$$

$$\therefore 174 \text{ g K}_2\text{SO}_4 \text{ requires } 32 \text{ g of S}$$

$$\therefore 1.743 \text{ g K}_2\text{SO}_4 \text{ requires } \frac{32 \times 1.743}{174} = 0.32 \text{ g of S}$$

Thus, given data confirms that (B) is K_2SO_4 .

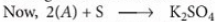

(A) potassium salt

$$\text{M. wt. of (A)} \times 2 = 142 \therefore \text{M. wt. of (A)} = 71$$

Since (A) is potassium salt

$$\therefore \text{Molecular weight of left component} = 71 - 39 = 32$$

Thus, salt is KO_2 .

2. (a)

3. (d) : The equilibrium given as,

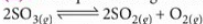

$$\therefore K_p = \frac{P_{\text{SO}_2}^2 P_{\text{O}_2}}{P_{\text{SO}_3}^2} = \frac{0.6 \times 0.6 \times 0.4}{0.3 \times 0.3} = 1.6 \text{ bar}$$

Upon adjustment, K_p does not change,

$$\therefore 1.6 \text{ bar} = K_p = \frac{x^2 P_{\text{O}_2}}{x^2}$$

Partial pressure of oxygen = 1.6 bar

4. (b)



Hydrated chloride on heating gives

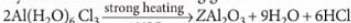

Al and Cl present in AlCl_3 . Thus,

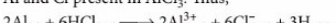

Thin protective layer of Al_2O_3 on the surface of metal causes passivation.



6. (a) : For the given reaction, $\text{N}_2 + 3\text{H}_2 \longrightarrow 2\text{NH}_3$

$$\text{Equivalent weight of } \text{N}_2(y_2) = x_2/6$$

$$\text{Equivalent weight of } \text{NH}_3(y_1) = x_1/3$$

$$y_1 - y_2 = \frac{x_1}{3} - \frac{x_2}{6} = \frac{2x_1 - x_2}{6}$$

7. (a)

8. (b) : According to first two of thermodynamics,

$$\Delta E = q + w$$

$$\text{For experiment I} \quad q = +100 \text{ J} \quad w = -200 \text{ J}$$

$$\Delta E = 100 - 200 = -100 \text{ J} = X$$

$$\text{For experiment II} \quad q = +200 \text{ J} \quad w = +200 \text{ J}$$

$$\Delta E = 200 + 200 = 400 \text{ J} = Y$$

$$\text{For experiment III} \quad q = -400 \text{ J} \quad w = -100 \text{ J}$$

$$\Delta E = -400 - 100 = -500 \text{ J} = Z$$

Thus, $Y > X > Z$.

9. (b) : $\text{C}_3\text{H}_8(\text{g}) + 3\text{H}_2\text{O}(\text{g}) \longrightarrow \underbrace{3\text{CO}(\text{g}) + 7\text{H}_2(\text{g})}_{\text{Syn gas}}$

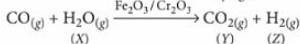

10. (d)

11. (b) : For gas $P_1 = (P_0 + h) \quad P_2 = (P_0 - h)$

$$V_1 = \pi r^2 \ell_1 \quad V_2 = \pi r^2 \ell_2$$

at const. T and moles.

$$P_1 V_1 = P_2 V_2 ; (P_0 + h) \pi r^2 \ell_1 = (P_0 - h) \pi r^2 \ell_2$$

$$P_0 \ell_1 + h \ell_1 = P_0 \ell_2 - h \ell_2 ; P_0 \ell_2 - P_0 \ell_1 = h \ell_1 + h \ell_2$$

$$P_0 = \left(\frac{h(\ell_1 + \ell_2)}{\ell_2 - \ell_1} \right) \text{ cm of Hg column}$$

12. (a)

$$13. (c) : M_{\text{avg}} = \frac{\sum_{j=1}^{j=n} n_j M_j}{\sum_{j=1}^{j=n} n_j} \quad \text{Here } \sum_{j=1}^{j=n} n_j = 100$$

$$M_{\text{avg}} = \frac{16 \times 32 + 80 \times 28 + 44 \times 3 + 64 \times 1}{100} = 29.48$$

14. (a) : Mass of $\text{BaSO}_4 = 0.582 \text{ g}$

$$\text{We know, } \text{BaSO}_4 = \text{S}$$

$$233 \text{ g of BaSO}_4 \text{ contains sulphur} = 32 \text{ g}$$

$$0.582 \text{ g of BaSO}_4 \text{ contains sulphur} = \frac{32}{233} \times 0.582$$

$$\text{Percentage of sulphur} = \frac{\text{wt. of sulphur}}{\text{wt. of compound}} \times 100$$

$$= \frac{32 \times 0.582}{233 \times 0.582} \times 100 = 20.24\%$$

15. (d) : $hc/\lambda = E_2 - E_1 = KE_2 - KE_1$

$$\therefore \lambda = \frac{h}{mV}, (mV)^2 = \left(\frac{h}{\lambda} \right)^2, \frac{1}{2} \frac{m^2 V^2}{m} = \frac{1}{2m} \frac{h^2}{\lambda^2}$$

$$\therefore \frac{hc}{\lambda} = \frac{h^2}{2m\lambda^2} - \frac{h^2}{2m\lambda_1^2} \therefore \lambda = \frac{2mc}{h} \left\{ \frac{\lambda_1^2 \lambda_2^2}{\lambda_1^2 - \lambda_2^2} \right\}$$

PRACTICE PAPER

NEET

Exam on
26th July 2020

1. IUPAC name of the compound,

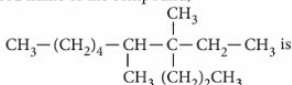

- (a) 3,4-dimethyl-3-*n*-propylnonane
 (b) 4-ethyl-4,5-dimethyldecane
 (c) 6,7-dimethyl-7-*n*-propylnonane
 (d) 6,7-dimethyl-7-ethyldecane.
2. Which of the following increasing order is not correct as mentioned in the property with it?
 (a) $\text{HClO} < \text{HClO}_2 < \text{HClO}_3 < \text{HClO}_4$
 (b) $\text{HClO}_4 < \text{HClO}_3 < \text{HClO}_2 < \text{HClO}$
 (c) $\text{F}^- < \text{Cl}^- < \text{Br}^- < \text{I}^-$
 (d) $\text{HIO}_4 < \text{ICl} < \text{I}_2 < \text{HI}$

3. Which of the following pairs of isomers is not correctly matched with its type of isomerism?

- (a) $[\text{Co}(\text{NH}_3)_6] [\text{Cr}(\text{CN})_6]$ and $[\text{Cr}(\text{NH}_3)_6] [\text{Co}(\text{CN})_6]$
 - Coordination isomerism
 (b) $[\text{Co}(\text{NH}_3)_5\text{NO}_2]\text{Cl}_2$ and $[\text{Co}(\text{NH}_3)_5\text{ONO}]\text{Cl}_2$
 - Linkage isomerism
 (c) $[\text{Co}(\text{py})_2(\text{H}_2\text{O})_2\text{Cl}_2]\text{Cl}$ and $[\text{Co}(\text{py})_2(\text{H}_2\text{O})\text{Cl}_3]\text{H}_2\text{O}$
 - Coordination isomerism
 (d) $[\text{Pt}(\text{NH}_3)_4\text{Br}_2]\text{Cl}_2$ and $[\text{Pt}(\text{NH}_3)_4\text{Cl}_2]\text{Br}_2$
 - Ionisation isomerism
4. Proteins are denatured in
 (a) mouth (b) stomach
 (c) small intestine (d) large intestine.

5. I, II, III are three isotherms respectively at T_1 , T_2 and T_3 . Temperature will be in order

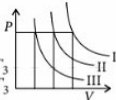

- (a) $T_1 = T_2 = T_3$ (b) $T_1 < T_2 < T_3$
 (c) $T_1 > T_2 > T_3$ (d) $T_1 > T_2 = T_3$

6. The correct order of increasing basic nature of the following bases is

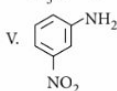
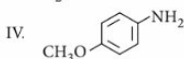
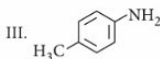
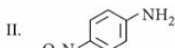
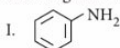

- (a) $\text{II} < \text{V} < \text{I} < \text{III} < \text{IV}$ (b) $\text{V} < \text{II} < \text{I} < \text{III} < \text{IV}$
 (c) $\text{II} < \text{V} < \text{I} < \text{IV} < \text{III}$ (d) $\text{V} < \text{II} < \text{I} < \text{IV} < \text{III}$

7. $\text{CH}_3 - \underset{\text{CH}_3}{\overset{\text{CH}_3}{\text{C}}} - \text{CH} = \text{CH}_2 \xrightarrow[\text{H}_2\text{O}_2, \text{OH}^-]{\text{B}_2\text{H}_6, \text{THF}} \text{A}$

The product A is

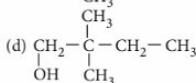
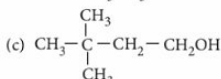
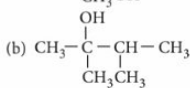
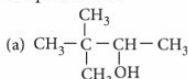

8. Phenol associates in benzene to a certain extent to form dimer. A solution containing 2.0×10^{-2} kg of

Last-minute check on your NEET readiness

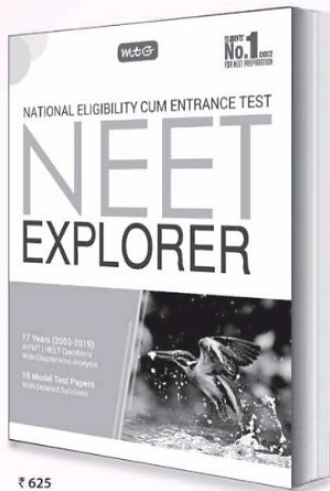

₹ 625



MTG's NEET Explorer helps students self-assess their readiness for success in NEET. Attempting the tests put together by MTG's experienced team of editors and experts strictly on the NEET pattern and matching difficulty levels, students can easily measure their preparedness for success. **Order now!**

HIGHLIGHTS:

- 10 Model Test Papers based on latest NEET syllabus
- Last 17 years' solved test papers of AIPMT/NEET
- Includes NEET 2019 solved paper
- Detailed solutions for self-assessment and to practice time management



Scan now with your smartphone or tablet*



Available at all leading book shops throughout India. For more information or for help in placing your order: Call 0124-6601200 or email: info@mtg.in

*Application to read QR codes required

Visit www.mtg.in for latest offers and to buy online!

phenol in 1.0 kg of benzene has its freezing point decreased by 0.69 K. The degree of association of phenol is (K_f for benzene = $5.12 \text{ K kg mol}^{-1}$)

- (a) 73.4% (b) 50.1% (c) 42.3% (d) 25.1%

9. Which of the following is not correct for ideal gas?

- (a) $\left(\frac{\partial U}{\partial V}\right)_T = 0$ (b) $\left(\frac{\partial H}{\partial P}\right)_T = 0$
 (c) $\left(\frac{\partial T}{\partial P}\right)_H = 0$ (d) $\left(\frac{\partial P}{\partial T}\right)_V = 0$

10. Among the following series of transition metal ions, the one where all metal ions have $3d^2$ electronic configuration is

- (a) $\text{Ti}^{3+}, \text{V}^{2+}, \text{Cr}^{3+}, \text{Mn}^{4+}$
 (b) $\text{Ti}^{4+}, \text{V}^{4+}, \text{Cr}^{6+}, \text{Mn}^{7+}$
 (c) $\text{Ti}^{4+}, \text{V}^{3+}, \text{Cr}^{2+}, \text{Mn}^{3+}$
 (d) $\text{Ti}^{2+}, \text{V}^{3+}, \text{Cr}^{4+}, \text{Mn}^{5+}$

11. If the equilibrium constants of the following equilibria,

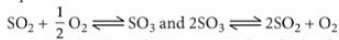

are given by K_1 and K_2 respectively, which of the following relation is correct?

- (a) $K_2 = \left(\frac{1}{K_1}\right)^2$ (b) $K_1 = \left(\frac{1}{K_2}\right)^3$
 (c) $K_2 = \left(\frac{1}{K_1}\right)$ (d) $K_2 = (K_1)^2$

12. Which of the following is an optically active compound?

- (a) 1-Butanol (b) 1-Propanol
 (c) 2-Chlorobutane (d) 4-Hydroxyheptane

13. Which one of the following products is formed when calcium salt of adipic acid is heated?

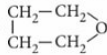
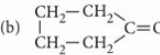
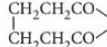
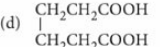
- (a)  (b) 
 (c)  (d) 

14. Which one of the following represents smallest quantity?

- (a) 1850 ng (b) $1.85 \times 10^{-4} \text{ g}$
 (c) $1.85 \times 10^3 \text{ } \mu\text{g}$ (d) $1.85 \times 10^{-6} \text{ kg}$

15. Which of the following systems is most stable for a chelate?

- (a) Two fused cyclic system
 (b) Three fused cyclic system
 (c) Four fused cyclic system
 (d) Five fused cyclic system

16. Which of the following exhibits aromaticity by using Huckel's rule?

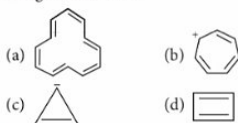

17. The order of reactivity of methyl halides in the formation of Grignard reagent is

- (a) $\text{CH}_3\text{I} > \text{CH}_3\text{Br} > \text{CH}_3\text{Cl}$
 (b) $\text{CH}_3\text{Cl} > \text{CH}_3\text{Br} > \text{CH}_3\text{I}$
 (c) $\text{CH}_3\text{Br} > \text{CH}_3\text{Cl} > \text{CH}_3\text{I}$
 (d) $\text{CH}_3\text{Br} > \text{CH}_3\text{I} > \text{CH}_3\text{Cl}$

18. The ionization enthalpies of second period elements vary with atomic numbers as

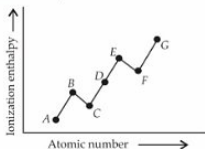

The elements present at points B and E are

- (a) Be, C (b) B, N (c) Be, O (d) Be, N

19. The structure of the compound that gives a tribromo derivative on treatment with bromine water is

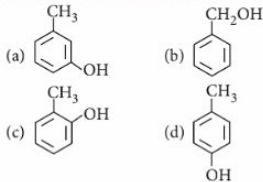

20. Two solutions of X and Y electrolytes are taken in two beakers and diluted by adding 500 mL of water. Λ_m of X increases by 1.5 times while that of Y increases by 20 times, what could be the electrolytes X and Y?

- (a) X - NaCl, Y - KCl
 (b) X - NaCl, Y - CH_3COOH
 (c) X - KOH, Y - NaOH
 (d) X - CH_3COOH , Y - NaCl

21. During adsorption the change in enthalpy is negative and the magnitude of negative value

- (a) goes on increasing
 (b) goes on decreasing
 (c) remains same
 (d) first increases then decreases.

22. C_2H_5OH and C_6H_5OH can be distinguished by

- (a) $Br_2 + H_2O$ (b) $FeCl_3$
 (c) $I_2 + NaOH$ (d) both (b) and (c).

23. Which transition in the hydrogen atomic spectrum will have the same wavelength as the transition, $n = 4$ to $n = 2$ of He^+ spectrum?

- (a) $n = 4$ to $n = 3$ (b) $n = 3$ to $n = 2$
 (c) $n = 4$ to $n = 2$ (d) $n = 2$ to $n = 1$

24. In the following Ellingham diagram X, Y and Z represents graph for metal oxides. Select the correct option.

- (a) Y will reduce oxide Z.
 (b) Y will reduce oxide X.
 (c) Z will reduce oxide X.
 (d) Z will reduce oxide Y.

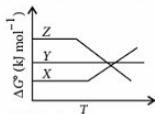

25. A salt on treatment with dilute HCl gives a pungent smelling gas and a yellow precipitate. The salt gives green-flame test and a yellow precipitate with potassium chromate. The salt is

- (a) $NiSO_4$ (b) BaS_2O_3 (c) PbS_2O_3 (d) $CuSO_4$

26. Match the column I with column II and mark the appropriate choice.

Column I

- (A) Electrical industry
 (B) Batteries
 (C) Gutter pipes
 (D) Gas stoves

Column II

- (i) Zinc
 (ii) Steel
 (iii) Copper
 (iv) Cast iron

- (a) (A) → (i), (B) → (ii), (C) → (iii), (D) → (iv)
 (b) (A) → (ii), (B) → (iii), (C) → (iv), (D) → (i)
 (c) (A) → (iv), (B) → (iii), (C) → (ii), (D) → (i)
 (d) (A) → (iii), (B) → (i), (C) → (iv), (D) → (ii)

27. An organic compound 'A' having molecular formula, C_2H_3N on reduction gave another compound 'B'. Upon treatment with nitrous acid 'B' gave ethyl alcohol. On warming with chloroform and alcoholic KOH, 'B' forms an offensive smelling compound 'C'. The compound 'C' is

- (a) $CH_3CH_2NH_2$ (b) $CH_3CH_2N \equiv C$
 (c) $CH_3C \equiv N$ (d) CH_3CH_2OH

28. Match the plots given in List I with their slopes given in List II and select the correct answer using the codes given below the lists :

List I

- P. C vs t (abscissa) for zero order reaction
 Q. $\log C$ vs t (abscissa) for first order reaction

List II

1. Unity
 2. Zero
 3. $-k$

- R. $\left(-\frac{dC}{dt}\right)$ vs C for zero order reaction

- S. $\ln\left(-\frac{dC}{dt}\right)$ vs $\ln C$ for first order reaction

P Q R S

- (a) 4 3 2 1
 (b) 3 4 2 1
 (c) 2 4 3 1
 (d) 3 2 4 1

29. The decreasing order of boiling points of the following hydrides is

- (a) $H_2O > SbH_3 > AsH_3 > PH_3 > NH_3$
 (b) $H_2O > NH_3 > SbH_3 > AsH_3 > PH_3$
 (c) $H_2O > SbH_3 > NH_3 > AsH_3 > PH_3$
 (d) $H_2O > PH_3 > AsH_3 > SbH_3 > NH_3$

30. Which of the following enzymes are used to convert starch into alcohol?

- (a) Maltase, diastase (b) Invertase, zymase
 (c) Diastase, maltase, zymase
 (d) Invertase, diastase, zymase

31. Which of the following represents the correct decreasing order of relative reactivity towards an electrophile, E^+ ?

- (a) $C_6H_5 - CH_3, p-CH_3 - C_6H_4 - CH_3, p-CH_3 - C_6H_4 - NO_2, p-NO_2 - C_6H_4 - NO_2$
 (b) $p-CH_3 - C_6H_4 - CH_3, p-CH_3 - C_6H_4 - NO_2, p-NO_2 - C_6H_4 - NO_2, C_6H_5 - CH_3$
 (c) $p-CH_3 - C_6H_4 - NO_2, C_6H_5 - CH_3, p-CH_3 - C_6H_4 - CH_3, p-NO_2 - C_6H_4 - NO_2$
 (d) $p-CH_3 - C_6H_4 - CH_3, C_6H_5 - CH_3, p-CH_3 - C_6H_4 - NO_2, p-NO_2 - C_6H_4 - NO_2$

32. A metal nitrate reacts with KI to give a black precipitate which on addition of excess of KI converts into orange colour solution. The cation of metal nitrate is

- (a) Hg^{2+} (b) Bi^{3+} (c) Pb^{2+} (d) Cu^+

33. An acid solution has a pH = 6. It is diluted 100 times, the pH of the resultant solution would be

- (a) 5.95 (b) 6.95 (c) 7 (d) 8

31. (d): $p\text{-CH}_3\text{-C}_6\text{H}_4\text{-CH}_3$ with two electron donating methyl groups is the most reactive, followed by $\text{CH}_3\text{-C}_6\text{H}_5$ with one methyl group. Out of the remaining, $p\text{-CH}_3\text{-C}_6\text{H}_4\text{-NO}_2$ with one electron withdrawing $-\text{NO}_2$ group is more reactive than $\text{NO}_2\text{-C}_6\text{H}_4\text{-NO}_2$ with two nitro groups.

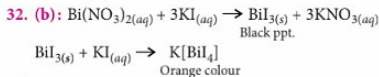

33. (b): $\text{pH} = 6$ or $[\text{H}^+] = 10^{-6}$; when it is diluted 100 times,

$$\text{i.e., } [\text{H}^+] = 10^{-6} \times 10^{-2} = 10^{-8}$$

But pH of an acid cannot exceed 7. Here we should also consider $[\text{H}^+]$ that comes from water.

Now $[\text{H}^+] = [\text{H}^+] \text{ from HCl} + [\text{H}^+] \text{ from H}_2\text{O}$

$$= 10^{-8} + 10^{-7} = 10^{-8} + 10 \times 10^{-8} = 11 \times 10^{-8}$$

$$\text{pH} = -\log(11 \times 10^{-8}) = -(1.0413 - 8) = 6.9587$$

34. (d): Histidine is the unique amino acid which contains imidazole ring.

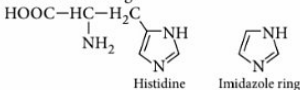

35. (a):

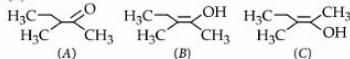

A , B and A , C are tautomers to each other. B and C are geometrical isomers as their methyl groups can be *cis* and *trans* position to each other. Also all geometrical isomers are diastereomers to each other.

36. (b): The complex which contains 18 valence electrons, follows 18-electron rule.

(a) $[\text{V}(\text{CO})_5]$: The number of valence electrons
 $= 5 + (2 \times 5) = 15 e^-$

(b) $[\text{Fe}(\text{NH}_3)_6]^{2+}$: The number of valence electrons
 $= 6 + (6 \times 2) = 6 + 12 = 18 e^-$

(c) $[\text{Ni}(\text{CO})_6]$: The number of valence electrons
 $= 10 + (2 \times 6) = 22 e^-$

(d) $[\text{Mn}(\text{H}_2\text{O})_6]^{2+}$: The number of valence electrons
 $= 5 + (6 \times 2) = 17 e^-$

Thus, only $[\text{Fe}(\text{NH}_3)_6]^{2+}$ follows 18-electron rule.

37. (c): Picric acid does not contain $-\text{COOH}$ group. It is 2, 4, 6-trinitrophenol.

38. (d): Total number of nodes = $n - 1$
 For d -orbital, radial nodes = $n - l - 1 = n - 3$ and there are 2 angular nodes.
 The number of angular nodes is given by l , i.e., for p , 1 angular node, for d , 2 angular nodes and so on.

39. (c): + 3 and + 4 states are shown by Ce in aqueous solution.

40. (b): The addition of α , β -unsaturated carbonyl compound, with conjugated diene is called Diels-Alder reaction.

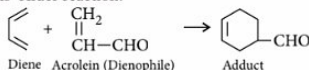

41. (d): The non-breakable plastic household crockery is made from copolymer of formaldehyde (HCHO) and melamine.

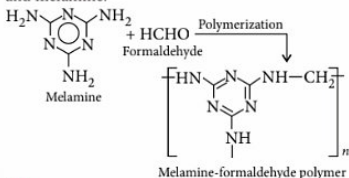

42. (d)

43. (c): H_2O is sp^3 hybridised with bond angle 104.5° due to presence of two lone pairs. OF_2 has structure similar to H_2O with bond angle 103° due to higher electronegativity of fluorine. OCl_2 also has similar structure with bond angle 111° because of steric crowding of two chlorine atoms. However, ClO_2 has π -bond character with an odd electron so that bond angle is 118° . Thus, four compounds can be arranged in order of their bond angles, as

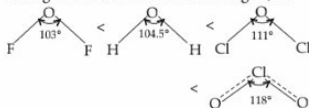

44. (b): $\text{CH}\equiv\text{CH} + \text{CH}_3\text{MgBr} \xrightarrow{-\text{CH}_4} \text{CH}\equiv\text{CMgBr}$

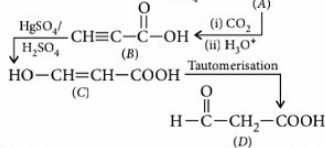

45. (b): Cellulase enzyme is present in the stomach of grazing mammals. It digests cellulose.

GET SET GO

JEE

for



with exclusive and brain storming MCQs

Practicing these MCQs help to strengthen your concepts and give you extra edge in your JEE preparation

Only One Option Correct Type

- Pure water is saturated with pure solid AgCl, a silver rod is placed in the solution and the potential is measured against normal calomel electrode at 25°C. This experiment is then repeated with a saturated solution of AgI. If the difference in potential is 0.177 V, what is the ratio of solubility product (K_{sp}) of AgCl and AgI at the temperature of the experiment? (In both cases normal calomel electrode is cathode)
(a) 10^3 (b) 10^6 (c) 10^{-3} (d) 10^{-6}
- pH of 0.1 M monobasic acid is measured to be 2. Its osmotic pressure at a given temperature T K is
(a) 0.1 RT (b) 0.11 RT
(c) 1.1 RT (d) 0.01 RT
- Which of the following will produce isopropyl amine?
I. $(\text{CH}_3)_2\text{CO} \xrightarrow{\text{NH}_2\text{OH}} \text{X} \xrightarrow{\text{LiAlH}_4}$
II. $\text{CH}_3 - \text{CH}_2 - \text{CHO} \xrightarrow[\text{heat}]{\text{NH}_3} \text{X} \xrightarrow{\text{LiAlH}_4}$
III. $(\text{CH}_3)_2\text{CH} - \text{OH} + \text{PCl}_5 \longrightarrow \text{X} \xrightarrow{\text{NH}_3}$
IV. $\text{CH}_3 - \text{CH}_2 - \text{CH}_2 - \text{NH}_2 \xrightarrow{\text{heat}}$
(a) I, II (b) II, III
(c) I, III (d) IV only
- Match each coordination compound in column I with an appropriate pair of characteristics in column II and select the correct answer using the code given below :

	Column I	Column II
A.	$[\text{Cr}(\text{NH}_3)_4\text{Cl}_2]\text{Cl}$	1. Paramagnetic and exhibits ionisation isomerism
B.	$[\text{Ti}(\text{H}_2\text{O})_5\text{Cl}](\text{NO}_3)_2$	2. Diamagnetic and exhibits <i>cis-trans</i> isomerism
C.	$[\text{Pt}(\text{en})(\text{NH}_3)\text{Cl}]\text{NO}_3$	3. Paramagnetic and exhibits <i>cis-trans</i> -isomerism
D.	$[\text{Co}(\text{NH}_3)_4(\text{NO}_3)_2]\text{NO}_3$	4. Diamagnetic and exhibits ionisation isomerism

- | | A | B | C | D |
|-----|---|---|---|---|
| (a) | 4 | 2 | 3 | 1 |
| (b) | 3 | 1 | 4 | 2 |
| (c) | 2 | 1 | 3 | 4 |
| (d) | 1 | 3 | 4 | 2 |
- Read the following reactions :
I. $\text{H}_3\text{C}-\overset{\text{O}}{\parallel}{\text{C}}-\text{OEt} \xrightarrow[\text{(ii) H}^+]{\text{(i) CH}_3\text{MgBr (excess)}}$
II. $\text{H}-\overset{\text{O}}{\parallel}{\text{C}}-\text{OEt} \xrightarrow[\text{(ii) H}^+]{\text{(i) PhMgBr (excess)}}$

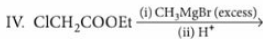
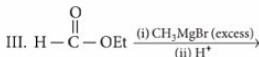

In which set of the reactions the product will be 3° alcohol?

- (a) I, II, III (b) I, III
(c) II, IV (d) I, IV

6. Consider the following isolation/purification processes.

I. Heating impure metal with I_2 at $150 - 200^\circ\text{C}$ and passing the resulting volatile iodide on hot tungsten filament at 1400°C to get the pure metal.

II. Heating the sulphide ore in air until a part is converted to oxide and then further heating in the absence of air to let the oxide react unchanged metal sulphide to get the metal.

III. Electrolysis of the molten electrolyte containing metal oxide and cryolite or fluorspar to obtain the metal.

The processes used for obtaining aluminium, titanium and lead are respectively

- (a) I, II and III (b) II, III and I
(c) III, I and II (d) II, I and III

7. An ester (A) with molecular formula, $\text{C}_9\text{H}_{10}\text{O}_2$ was treated with excess of CH_3MgBr and the complex so formed was treated with H_2SO_4 to give an olefin (B). Ozonolysis of (B) gave a ketone with molecular formula $\text{C}_8\text{H}_8\text{O}$ which shows +ve iodoform test. The structure of (A) is

- (a) $\text{C}_6\text{H}_5\text{COOC}_2\text{H}_5$
(b) $\text{C}_2\text{H}_5\text{COOC}_6\text{H}_5$
(c) $\text{H}_3\text{COCH}_2\text{COC}_6\text{H}_5$
(d) $p - \text{H}_3\text{CO} - \text{C}_6\text{H}_4 - \text{COCH}_3$

8. A certain hypohalite on treating with hot and conc. NaOH forms anions P and Q. Stable anion among P and Q can be obtained by neutralising its conjugate acid X.

Upon heating to very high temperature a compound Y is formed, which is used in estimation of a toxic gas which have 300 times stronger affinity for haemoglobin than dioxygen. Then which of the following statements are true?

- (a) X is HI.
(b) Y is Cl_2O_5
(c) Final product, Y has total no. of bonds 5.

(d) Y on reacting with the toxic gas produces a gas which is used in fire extinguisher.

9. The density of solid argon is 1.65 g/mL at -233°C . If the argon atom is assumed to be sphere of radius $1.54 \times 10^{-8} \text{ cm}$, what percentage of solid argon is apparently empty space?

- (a) 62% (b) 38% (c) 50% (d) 84%

10. The pair of compounds in which both the compounds give positive test with Tollens' reagent is
(a) glucose and sucrose (b) fructose and sucrose
(c) acetophenone and hexanal
(d) glucose and fructose.

More Than One Options Correct Type

11. $4 \text{ AgNO}_3 + 2 \text{ H}_2\text{O} + \text{H}_3\text{PO}_2 \xrightarrow{\text{boil}} 4 \text{ Ag} + \text{X} + \text{Y}$
If X is oxyacid of nitrogen and Y is oxyacid of phosphorous then correct statement(s) is/are

- (a) X is HNO_3 (b) Y is H_3PO_4
(c) the oxidation number of 'P' changed from +1 to +5
(d) all of these.

12. Which compound in each of the following pairs is most reactive to the conditions indicated?

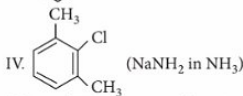
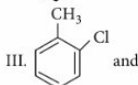
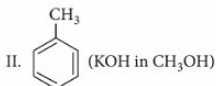
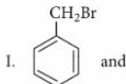

- (a) I and III (b) II and III
(c) I and IV (d) II and IV

Quotable Quote

You cannot teach a man anything; you can only help him discover it in himself.

Galileo

13. For a first order reaction, $nA \longrightarrow B$ whose concentration vs time curve is as shown in the figure. If half life for the reaction is 24 minutes. Find out the value of n .

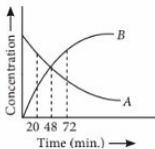

- (a) 1 (b) 2 (c) 3 (d) 4
14. Select the correct statement.
- Langmuir adsorption isotherm is expected to be applicable at low gas pressure and moderately high temperature.
 - The rate of an enzyme catalysed reaction depends upon enzyme concentration.
 - A negative catalyst raises the activation energy barrier of a reaction and thus reduces its rate.
 - Gases having lower critical temperature are adsorbed to a greater extent than those with higher critical temperature.
15. $\text{FeCr}_2\text{O}_4 + \text{Na}_2\text{CO}_3 + \text{O}_2 \xrightarrow{\text{Fusion}} (X) \xrightarrow[\text{H}_2\text{O}]{\text{H}^+} (Y) \xrightarrow[\text{H}_2\text{O}_2]{\text{H}^+} (Z)$

Which of the following statement is true for the compounds (X), (Y) and (Z)?

- In all three compounds, the chromium is in +6 oxidation state.
- (Z) is a deep blue-violet coloured compound which decomposes rapidly in aqueous solution into Cr^{3+} and dioxygen.
- Saturated solution of (Y) gives bright orange compound, chromic anhydride, with concentrated H_2SO_4 .
- All of these.

SOLUTIONS

1. (b): $\text{Ag} \longrightarrow \text{Ag}^+ + e^-$

$$E_1 = E_{\text{oxid}} + E_{\text{calomel}}$$

$$= E' - \frac{0.0591}{1} \log \sqrt{K_{sp1}} + E_{\text{calomel}}$$

$$E_2 = E' - \frac{0.0591}{1} \log \sqrt{K_{sp2}} + E_{\text{calomel}}$$

$$E_2 - E_1 = 0.177 = 0.0591 \log \frac{\sqrt{K_{sp1}}}{\sqrt{K_{sp2}}} \Rightarrow \frac{K_{sp1}}{K_{sp2}} = 10^6$$

2. (b): $\text{HA} \rightleftharpoons \text{H}^+ + \text{A}^-$

$$t = 0 \quad 0 \quad 0 \quad 0$$

$$t_{\text{eq}} \quad C - C\alpha \quad C\alpha \quad C\alpha$$

$$[\text{H}^+] = C\alpha, [\text{H}^+] = 10^{-\text{pH}}$$

$$\therefore C\alpha = 10^{-2}$$

$$0.1 \alpha = 10^{-2} \Rightarrow \alpha = 0.1$$

$$\alpha = \frac{i-1}{n-1}; 0.1 = \frac{i-1}{2-1}$$

$$i = 1.1$$

$$\therefore \pi = iCRT = 1.1 \times 0.1 \times RT = 0.11 RT$$

3. (c): $(\text{CH}_3)_2\text{CO} \xrightarrow{\text{NH}_2\text{OH}} (\text{CH}_3)_2\text{C}=\text{N}-\text{OH}$
 $\downarrow \text{LiAlH}_4$
 $(\text{CH}_3)_2\text{CHNH}_2$
 $(\text{CH}_3)_2\text{CHOH} \xrightarrow{\text{PCl}_5} (\text{CH}_3)_2\text{CHCl} \xrightarrow{\text{NH}_3} (\text{CH}_3)_2\text{CHNH}_2$
4. (b): (A) $[\text{Cr}(\text{NH}_3)_4\text{Cl}_2]\text{Cl} \rightarrow \text{Cr}^{+3}$ is d^3 . It is paramagnetic and it shows *cis-trans* isomerism.
 (B) $[\text{Ti}(\text{H}_2\text{O})_5\text{Cl}](\text{NO}_3)_2 \rightarrow \text{Ti}^{+3}$ is d^1 . It is paramagnetic and it show ionisation isomerism.
 (C) $[\text{Pt}(\text{en})(\text{NH}_3)\text{Cl}]\text{NO}_3 \rightarrow \text{Pt}^{+2}$ is d^8 . But this complex is square planar and all electrons are paired. So it is diamagnetic. It exhibit ionisation isomerism.
 (D) $[\text{Co}(\text{NH}_3)_4(\text{NO}_2)_2]\text{NO}_3 \rightarrow \text{Co}^{+3}$ is d^6 . Since ligands are strong, so electron are paired. It is diamagnetic. It exhibit *cis-trans* isomerism.

5. (d): I. $\text{H}-\overset{\text{O}}{\parallel}{\text{C}}-\text{OEt} \xrightarrow[\text{(ii) H}^+]{\text{(i) CH}_3\text{MgBr(excess)}}$
- $$\begin{array}{c} \text{OH} \\ | \\ \text{CH}_3-\text{C}-\text{CH}_3 \\ | \\ \text{CH}_3 \\ \text{(3}^\circ \text{ alcohol)} \end{array}$$
- II. $\text{H}-\overset{\text{O}}{\parallel}{\text{C}}-\text{OEt} \xrightarrow[\text{(ii) H}^+]{\text{(i) PhMgBr(excess)}}$
- $$\begin{array}{c} \text{OH} \\ | \\ \text{H}-\text{C}-\text{Ph} \\ | \\ \text{Ph} \\ \text{(2}^\circ \text{ alcohol)} \end{array}$$
- III. $\text{H}-\overset{\text{O}}{\parallel}{\text{C}}-\text{OEt} \xrightarrow[\text{(ii) H}^+]{\text{(i) CH}_3\text{MgBr(excess)}}$
- $$\begin{array}{c} \text{OH} \\ | \\ \text{H}-\text{C}-\text{CH}_3 \\ | \\ \text{CH}_3 \\ \text{(2}^\circ \text{ alcohol)} \end{array}$$
- IV. $\text{ClCH}_2\text{COOEt} \xrightarrow[\text{(ii) H}^+]{\text{(i) CH}_3\text{MgBr(excess)}}$
- $$\begin{array}{c} \text{OH} \\ | \\ \text{Cl}-\text{CH}_2-\text{C}-\text{CH}_3 \\ | \\ \text{CH}_3 \\ \text{(3}^\circ \text{ alcohol)} \end{array}$$

6. (c)

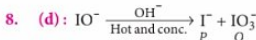
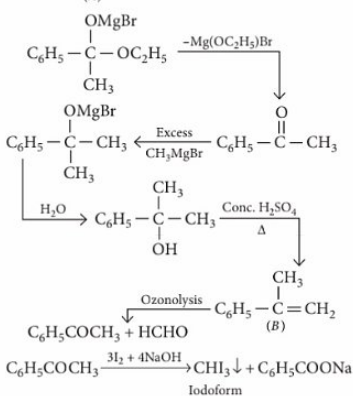
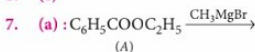

Q is more stable anion its conjugate acid is HIO_3 .

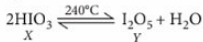

(Useful in fire extinguishing)

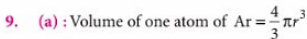

Also, number of atoms in 1.65 g or one mL

$$= \frac{1.65}{40} \times 6.023 \times 10^{23}$$

\therefore Total volume of all atoms of Ar in solid state

$$= \frac{4}{3}\pi r^3 \times \frac{1.65}{40} \times 6.023 \times 10^{23}$$

$$= \frac{4}{3} \times \frac{22}{7} \times (1.54 \times 10^{-8})^3 \times \frac{1.65}{40} \times 6.023 \times 10^{23}$$

$$= 0.380 \text{ cm}^3$$

Volume of solid argon = 1 cm^3

$$\therefore \% \text{ empty space} = \frac{[1 - 0.380]}{1} \times 100 = 62\%$$

10. (d) : Glucose being an aldose responds to Tollens' test while fructose, although a ketose, undergoes rearrangement in presence of basic medium

(provided by Tollens' reagent) to form glucose, which then responds to Tollens' test.

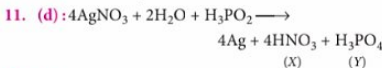

12. (a) : In the first case the reaction gives side chain substitution product which is easier in A. In the second case the reaction will proceed by benzyne mechanism for which *ortho* position w.r.t. Cl must have H-atoms.



$$a - x \quad x/n \quad t_{1/2} = 24 \text{ min}$$

$$\text{at } t = 48 \quad a - x = \frac{x}{n}$$

$$a = \frac{(1+n)x}{n}; \frac{na}{1+n} = x$$

$$\frac{\ln 2}{24} = \frac{1}{48} \ln \frac{a}{a - \frac{na}{1+n}} \Rightarrow 4 = \frac{a(1+n)}{a} \Rightarrow n = 3$$

14. (c)

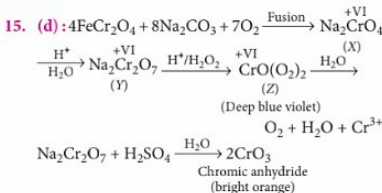

COMIC CAPSULE

DON'T DRINK WATER WHILE STUDYING. BECAUSE CHEMISTRY SAYS THAT



CONCENTRATION DECREASES ON ADDING WATER

- Converting *n*-hexane into benzene in the presence of chromium oxide on alumina support is an example of a/an
 - hydrogenation reaction
 - isomerisation reaction
 - dehydrogenation reaction
 - substitution reaction.

- Oxidation of benzene with air at 725 K in presence of V_2O_5 as catalyst gives
 - maleic acid
 - malic acid
 - malonic acid
 - maleic anhydride.

- Identify *X* in the following reaction sequence :

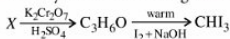

- $\text{CH}_3\text{CH}_2\text{CH}_2\text{OH}$
 - $\text{CH}_3\text{CHOHCH}_3$
 - $\text{CH}_3\text{OCH}_2\text{CH}_3$
 - $\text{CH}_3\text{CH}_2\text{CHO}$
- In a reaction which is carried out at 400 K, 0.0001% of the total number of collisions are effective. The energy of activation of the reaction is
 - zero
 - 7.37 kcal/mol
 - 9.212 kcal/mol
 - 11.05 kcal/mol

- Phenol gives *sym*-tribromophenol when treated with bromine in aqueous solution but only *o*- and *p*-bromophenols in CCl_4 solution because
 - in aqueous solution the bromine is ionised
 - in aqueous solution, phenol exists in equilibrium with phenoxide ion which has more activating effect
 - in CCl_4 , the electrophilicity of Br_2 increases
 - in CCl_4 , the other positions of benzene rings are blocked by the solvent.

- For the following conversion,

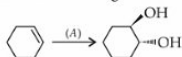

reagent (A) is

- OsO_4
- O_3

- I_2 and silver acetate under wet condition
- peracid following by acid hydrolysis.

- Identify *A*, *B* and *C* in the following reaction sequence :

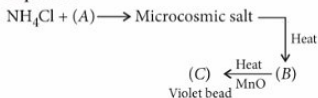

- Na_3PO_4 , NaPO_3 , $\text{Mn}_3(\text{PO}_4)_2$
 - Na_2HPO_4 , Na_3PO_4 , $\text{Mn}_3(\text{PO}_4)_2$
 - Na_2HPO_4 , NaPO_3 , $\text{Mn}(\text{PO}_3)_2$
 - Na_2HPO_4 , NaPO_3 , NaMnPO_4
- Which of the following is an incorrect statement?
 - Non-ionic detergents are neutral.
 - The hydrophilic portion of a non-ionic detergent functions by a hydrogen bonding mechanism.
 - Cationic detergents have a positively charged water soluble portion.
 - LABS detergent are not biodegradable.
 - For the complex, $[\text{Co}(\text{NH}_3)_5\text{CO}_3]\text{ClO}_4$ the coordination number, oxidation number, number of *d*-electrons and number of unpaired electrons on the metal are, respectively
 - 6, 3, 6, 0
 - 7, 2, 7, 1
 - 7, 1, 6, 4
 - 6, 3, 6, 4

- The structure of the tetrathionate ion is

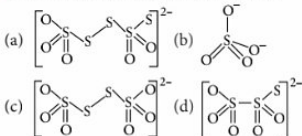

- The dipole moment of HBr is 0.78×10^{-18} esu cm and interatomic spacing is 1.41 Å. The % ionic character of HBr is
 - 7.5
 - 11.5
 - 15
 - 27

12. The disperse phase in colloidal iron(III) hydroxide and colloidal gold is positively and negatively charged respectively. Which of the following is not correct?

- (a) Magnesium chloride solution coagulates the gold sol more readily than iron(III) hydroxide sol.
 (b) Sodium sulphate solution causes coagulation in both sols.
 (c) Mixing of the sols has no effect.
 (d) Coagulation in both sols can be brought about by electrophoresis.

13. In a cubic crystal of CsCl (density = 3.97 g/cm^3) the eight corners are occupied by Cl^- ions with Cs^+ ions at the centre. The distance between the neighbouring Cs^+ and Cl^- ions is

- (a) 4.21 \AA (b) 3.00 \AA (c) 3.57 \AA (d) 4.57 \AA

14. The type of hybrid orbitals used by chlorine atom in ClO_2^+ is

- (a) sp^3 (b) sp^2
 (c) sp (d) none of these.

15. If $\Delta G = \Delta H - T\Delta S$ and $\Delta G = \Delta H + T \left[\frac{d(\Delta G)}{dT} \right]_p$ then variation of EMF of a cell, with temperature T , is given by

- (a) $\frac{\Delta S}{nF}$ (b) $-\frac{\Delta S}{nF}$ (c) $\frac{\Delta H}{nF}$ (d) $\frac{\Delta G}{nF}$

16. When K_2CrO_4 is added to CuSO_4 solution, there is formation of CuCrO_4 and CuCr_2O_7 . Formation of CuCr_2O_7 is due to

- (a) basic nature of CuSO_4 solution which converts CrO_4^{2-} to $\text{Cr}_2\text{O}_7^{2-}$
 (b) acidic nature of CuSO_4 solution which converts CrO_4^{2-} to $\text{Cr}_2\text{O}_7^{2-}$
 (c) CuSO_4 has a typical property of converting CrO_4^{2-} to $\text{Cr}_2\text{O}_7^{2-}$
 (d) none of the above is correct.

17. Time taken for an electron to complete one revolution in the Bohr orbit of hydrogen atom is

- (a) $\frac{4\pi^2 m r^2}{nh}$ (b) $\frac{nh}{4\pi^2 m r}$
 (c) $\frac{2\pi m r}{n^2 h^2}$ (d) $\frac{h}{2\pi m r}$

18. The acid used for the determination of molecular weight of amines is

- (a) H_2PtCl_6 (b) picric acid
 (c) HAuCl_4 (d) H_2SO_4

19. A complex of a certain metal ion has a magnetic moment of 4.90 B.M. Another complex of the same metal in the same oxidation state has a zero magnetic moment. The central metal ion could be

- (a) Cr^{3+} (b) Mn^{2+} (c) Fe^{3+} (d) Fe^{2+}

20. Which of the following reactions is a condensation reaction?

- (a) $\text{HCHO} \longrightarrow$ Paraformaldehyde
 (b) $\text{CH}_3\text{CHO} \longrightarrow$ Paraldehyde
 (c) $\text{CH}_3\text{COCH}_3 \longrightarrow$ Mesityl oxide
 (d) $\text{CH}_2 = \text{CH}_2 \longrightarrow$ Polyethylene

NUMERICAL VALUE TYPE

21. The reaction, $2\text{AB}_{(g)} + 2\text{C}_{(g)} \rightarrow \text{A}_2\text{C}_{(g)} + 2\text{BC}_{(g)}$, proceeds according to the mechanism :

- (I) $2\text{AB} \rightleftharpoons \text{A}_2\text{B}_2$ (fast)
 (II) $\text{A}_2\text{B}_2 + \text{C} \longrightarrow \text{A}_2\text{B} + \text{BC}$ (slow)
 (III) $\text{A}_2\text{B} + \text{C} \longrightarrow \text{A}_2 + \text{BC}$ (fast)

The K_c for the step I is 10^2 M^{-1} and rate constant for the step II is $3.0 \times 10^{-3} \text{ mol}^{-1} \text{ L min}^{-1}$.

The initial rate taking $[\text{AB}] = 0.2 \text{ M}$ and $[\text{C}] = 0.5 \text{ M}$ will be $x \times 10^{-3} \text{ M min}^{-1}$. The value of x is _____.

22. When A_2 and B_2 are allowed to react, the equilibrium constant of the reaction at 27°C is found ($K_c = 4$).

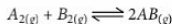
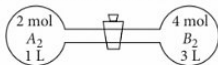

The equilibrium concentration of AB will be _____.

23. The longest wavelength doublet absorption transition is observed at 589 and 589.6 nm. Energy difference between two excited states is $x \times 10^{-25} \text{ kJ}$. The value of x is _____.

24. The pH at which $\text{Mg}(\text{OH})_2$ begins to precipitate from a solution containing 0.1 M Mg^{2+} ions is _____. [K_{sp} for $\text{Mg}(\text{OH})_2 = 1.0 \times 10^{-11}$]

25. A 2 L vessel is filled with air at 50°C and a pressure of 3 atm. The temperature is now raised to 200°C . A valve is now opened so that the pressure inside drops to one atm. The fraction of the total number of moles, inside escaped on opening the valve will be _____. (Assume no change in the volume of the container).

SOLUTIONS

1. (c) : Conversion of *n*-hexane into benzene involves removal of six H-atoms. Therefore, this process is either called dehydrogenation or aromatization.

2. (d) :

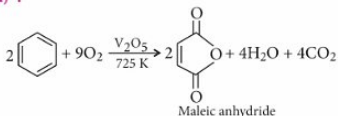

3. (b) : Since $\text{C}_3\text{H}_6\text{O}$ on treatment with $\text{I}_2 + \text{NaOH}$ gives CHI_3 , therefore, $\text{C}_3\text{H}_6\text{O}$ must be a dimethyl ketone, i.e., CH_3COCH_3 . If this is so then, X must be $\text{CH}_3\text{CHOHCH}_3$.

4. (d) : $f = e^{-E_a/RT}$

$$\ln \frac{1}{f} = \frac{E_a}{RT} \Rightarrow \ln \frac{1}{0.0001 \times \frac{1}{100}} = \frac{E_a}{2 \times 400}$$

$$E_a = 11.05 \text{ kcal/mol}$$

5. (b) : In aqueous solution, phenol ionises to form phenoxide ion. Due to the presence of negative charge, the oxygen of the phenoxide ion donates electrons to the benzene ring to a large extent. As a result, the ring gets highly activated and hence, trisubstitution occurs.

On the other hand, in non-polar solvents the ionization of phenol is greatly suppressed. Consequently, the ring is activated only slightly and hence, only monosubstitution occurs.

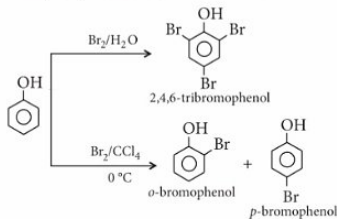

6. (d) : Hydroxylation of alkene using $\text{H}_2\text{O}_2/\text{HCO}_2\text{H}$ (peracid) is *anti*-addition.

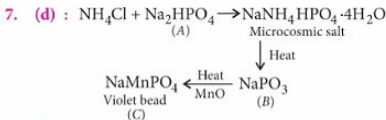
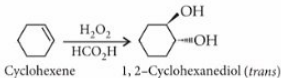

8. (d) : All LABS detergents are not biodegradable and some of them cause pollution and are hazardous to human civilization.

9. (a) : Coordination number of Co in $[\text{Co}(\text{NH}_3)_5\text{CO}_3]\text{ClO}_4 = 6$
Oxidation number of Co in $[\text{Co}(\text{NH}_3)_5\text{CO}_3]^+$
 $\Rightarrow x - 2 = +1 \Rightarrow x = +3$

$$\text{Co}^{3+} (Z = 27) : 3d^6$$

∴ Number of *d*-electrons = 6

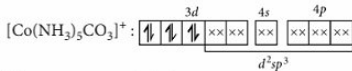

There are no unpaired electrons.

10. (c) : Tetrathionate ion ($\text{S}_4\text{O}_6^{2-}$) :

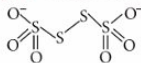

11. (b) : Dipole moment of HBr (when 100% ionic)
 $= 4.8 \times 10^{-10} \times 1.41 \times 10^{-8} \text{ cm}$
 $= 6.768 \times 10^{-18} \text{ esu cm}$

Actual dipole moment = $0.78 \times 10^{-18} \text{ esu cm}$

∴ % ionic character

$$= \frac{0.78 \times 10^{-18}}{6.768 \times 10^{-18}} \times 100 = 11.52 \approx 11.5$$

12. (c) : When positive and negative sols are mixed, they coagulate each other.

13. (c) : In a unit cell, there is one Cs^+ (from body centre) and $\left(\frac{1}{8} \times 8 = 1\right)$ one Cl^- , i.e., one CsCl molecule.

$$\therefore \rho = \frac{Z \times M}{a^3 \times N_A}$$

$$\therefore 3.97 = \frac{1 \times 168.36}{a^3 \times 6.023 \times 10^{23}}$$

$$\Rightarrow a = 4.13 \times 10^{-8} \text{ cm} = 4.13 \text{ \AA}$$

For a cube of side length 4.13 Å,

$$\text{Diagonal} = \sqrt{3}a = \sqrt{3} \times 4.13 = 7.15 \text{ \AA}$$

As it is a *bcc* with Cs^+ at centre (radius r^+) and Cl^- at corners (radius r^-), so

BEST TOOLS FOR SUCCESS IN

JEE Main

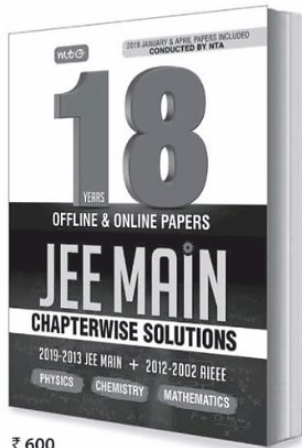
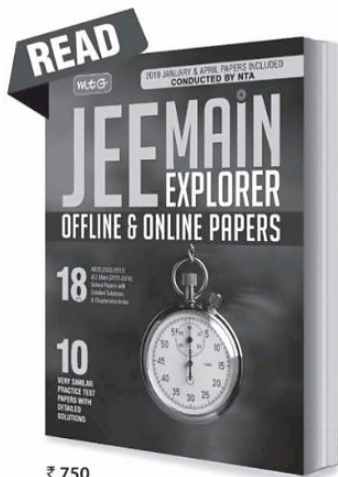

10 Very Similar Practice Test Papers with Detailed Solutions

18 JEE MAIN 2019-2015(Offline & Online)-2013 & AIEEE (2012-2002)
Years



Available at all leading book shops throughout India.
For more information or for help in placing your order:
Call 0124-6601200 or email: info@mtg.in

Visit
www.mtg.in
for latest offers
and to buy
online!

$2r^+ + 2r^- = 7.15 \text{ \AA}$ or $r^+ + r^- = 3.57 \text{ \AA}$
 i.e., Distance between neighbouring Cs^+ and Cl^- = 3.57 \AA

14. (a) : Hybridisation (H) = $GA + (VE - V - C)/2$

GA = Group atoms attached to central atom

VE = Valence electrons of central atom

V = Valency of central atom

C = Charge over the molecule

$$\therefore H = 3 + (7 - 6 - (-1))/2 = 4$$

As molecule is having hybridisation number 4. So, it has sp^3 hybridisation.

15. (a) : On comparison,

$$\Delta S = - \left[\frac{d(\Delta G)}{dT} \right]; \Delta S = - \frac{d(-nFE)}{dT} = nF \left(\frac{dE}{dT} \right)$$

$$\therefore \left(\frac{dE}{dT} \right) = \frac{\Delta S}{nF}$$

16. (b)

17. (a) : By Bohr's postulate,

$$mvr = n \frac{h}{2\pi} \quad \text{or,} \quad v = \frac{nh}{2\pi mr}$$

No. of revolutions per second

$$= \frac{\text{velocity}}{\text{circumference of the orbit}}$$

$$= \frac{v}{2\pi r} = \frac{nh}{2\pi mr} \times \frac{1}{2\pi r} = \frac{nh}{4\pi^2 mr^2}$$

$$\therefore \text{Time taken for one revolution} = \frac{4\pi^2 mr^2}{nh}$$

18. (a) : The acid used is H_2PtCl_6 . It is a solution of platinum chloride, PtCl_4 in conc. HCl.

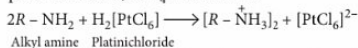

Alkyl amine Platinchloride

Chloroplatinates on ignition leave a residue of metallic platinum. This reaction is employed in determining molecular weight of amines.

19. (d) : Magnetic moment = 4.90 B.M. ; 4 unpaired electrons

Magnetic moment = 0 ; 0 unpaired electron

To have either four or zero unpaired electrons, the configuration must be d^6 . Hence, the central metal ion should be Fe^{2+} .

20. (c) : The formation of mesityl oxide from acetone is a condensation reaction. On treatment with conc. NaOH in the presence of dry HCl gas, acetone forms mesityl oxide through the intermediate formation of diacetone alcohol.

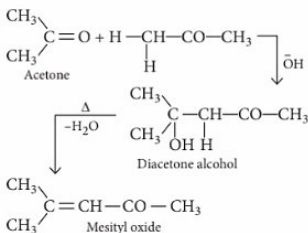

21. (6) : Rate of reaction = Rate of step II
 (the slowest step)
 $\Rightarrow \text{Rate of reaction} \propto [\text{A}_2\text{B}_2][\text{C}] = k[\text{A}_2\text{B}_2][\text{C}] \dots(i)$

where, k , is the rate constant

The equilibrium constant, K_c for the step I is

$$K_c = \frac{[\text{A}_2\text{B}_2]}{[\text{AB}]^2} \Rightarrow [\text{A}_2\text{B}_2] = K_c [\text{AB}]^2$$

Putting this in equation (i), we get

$$\begin{aligned} \text{Rate of reaction} &= k \cdot K_c [\text{AB}]^2 [\text{C}] \\ &= k' [\text{AB}]^2 [\text{C}] \\ &\propto [\text{AB}]^2 [\text{C}] \dots(ii) \end{aligned}$$

where $k' = k \cdot K_c$ = rate constant of reaction.

Equation (ii) is the rate law of reaction,

$$\begin{aligned} \text{initial rate} &= 3.0 \times 10^{-3} \times 10^2 \times (0.2)^2 (0.5) \\ &= 0.3 \times 0.04 \times 0.5 = 0.006 \text{ M min}^{-1} \\ &= 6 \times 10^{-3} \text{ M min}^{-1} \end{aligned}$$

22. (0.66): $\text{A}_{2(g)} + \text{B}_{(g)} \rightleftharpoons 2\text{AB}_{(g)}$

$$\begin{array}{ccc} t_0 & \frac{2}{4} & \frac{4}{4} & 0 \\ t_{eq} & \frac{2-x}{4} & \frac{4-x}{4} & \frac{2x}{4} \end{array}$$

$$K_c = \frac{[\text{AB}]^2}{[\text{A}_2][\text{B}_2]}$$

$$4 = \frac{[2x/4]^2}{\left(\frac{2-x}{4}\right)\left(\frac{4-x}{4}\right)} \Rightarrow 4 = \frac{4x^2}{x^2 - 6x + 8}$$

Monthly Test Drive CLASS XII ANSWER KEY

1. (b) 2. (c) 3. (d) 4. (d) 5. (d)
 6. (c) 7. (d) 8. (c) 9. (c) 10. (a)
 11. (d) 12. (c) 13. (a) 14. (b) 15. (c)
 16. (c) 17. (d) 18. (b) 19. (c) 20. (c,d)
 21. (b,c) 22. (a,c,d) 23. (a,b,c,d) 24. (4) 25. (2)
 26. (7) 27. (c) 28. (c) 29. (c) 30. (b)

$$x^2 - 6x + 8 = x^2, \therefore x = \frac{4}{3}$$

$$[AB] = \frac{2x}{4} = \frac{2}{4} \times \frac{4}{3} = 0.66 \text{ M}$$

23. (3.31): Step I: Wavelength (λ) = 589 nm
 $= 589 \times 10^{-9} \text{ m}$

$$\text{Frequency } (\nu) = \frac{c}{\lambda} = \frac{3 \times 10^8}{589 \times 10^{-9}}$$

$$= 5.093 \times 10^{14} \text{ cycles per sec}$$

Step II: Wavelength (λ) = 589.6 nm = $589.6 \times 10^{-9} \text{ m}$

$$\therefore \nu = \frac{c}{\lambda} = \frac{3 \times 10^8}{589.6 \times 10^{-9}}$$

$$= 5.088 \times 10^{14} \text{ cycles per sec}$$

Energy difference between two excited states,

$$\Delta E = 6.626 \times 10^{-34} (5.093 - 5.088) 10^{14}$$

$$= 6.626 \times 10^{-34} \times 5 \times 10^{-3} \times 10^{14} = 3.31 \times 10^{-22} \text{ J}$$

$$= 3.31 \times 10^{-25} \text{ kJ}$$

24. (9) : K_{sp} for $\text{Mg}(\text{OH})_2 = 1.0 \times 10^{-11}$
 $[\text{Mg}^{2+}] [\text{OH}^-]^2 = (0.1) \times [\text{OH}^-]^2 = 1.0 \times 10^{-11}$
 $[\text{OH}^-]^2 = \frac{1 \times 10^{-11}}{0.1} = 10^{-10}$
 $[\text{OH}^-] = 10^{-5}; [\text{H}^+] = \frac{10^{-14}}{10^{-5}} = 10^{-9}; \text{pH} = 9$

25. (0.77): Given that, $V = 2 \text{ L}$,
 $T_1 = 50 + 273 = 323 \text{ K}, P_1 = 3 \text{ atm}$
 On heating $V = 2 \text{ L}$
 $T_2 = 200 + 273 = 473$
 $P_2 = ?$

$$\text{Using } P-T \text{ law, } \frac{P_1}{T_1} = \frac{P_2}{T_2}$$

$$P_2 = \frac{3 \times 473}{323} = 4.39 \text{ atm}$$

$$\text{and } n = \frac{PV}{RT} = \frac{3 \times 2}{0.0821 \times 323} = 0.226$$

Now valve is opened till the pressure is maintained at 1 atm.

Thus, at constant V and $T, P \propto n$

$$\therefore P_2 \propto n \therefore 1 \propto n_{\text{left}}$$

$$\therefore \frac{P_2}{1} = \frac{n}{n_{\text{left}}} \therefore n_{\text{left}} = \frac{0.226}{4.39} = 0.052$$

$$\therefore \text{Moles escaped out} = 0.226 - 0.052 = 0.174$$

$$\therefore \text{Fraction of moles escaped out} = \frac{0.174}{0.226} = 0.77$$



AVAILABLE BOUND VOLUMES

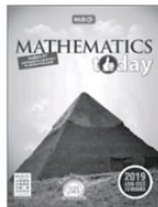
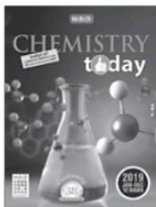
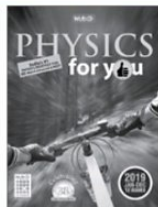

Physics For You 2019 (January - December)	₹ 380 12 issues
Chemistry Today 2019 (January - December)	₹ 380 12 issues
Mathematics Today 2019 (January - December)	₹ 380 12 issues
Biology Today 2019 (January - December)	₹ 380 12 issues
Physics For You 2018 (January - December)	₹ 380 12 issues
Chemistry Today 2018 (January - December)	₹ 380 12 issues
Mathematics Today 2018 (January - December)	₹ 380 12 issues
Biology Today 2018 (January - December)	₹ 380 12 issues
Physics For You 2017 (January - December)	₹ 325 12 issues
Chemistry Today 2017 (January - December)	₹ 325 12 issues
Mathematics Today 2017 (January - December)	₹ 325 12 issues
Biology Today 2017 (January - December)	₹ 325 12 issues
Physics For You 2016 (January - June)	₹ 175 6 issues
Mathematics Today 2016 (January - December)	₹ 325 12 issues
Biology Today 2016 (January - June)	₹ 175 6 issues
Chemistry Today 2016 (January - June)	₹ 175 6 issues

of your favourite
magazines

How to order : Send money by demand draft/money order. Demand Draft should be drawn in favour of **MTG Learning Media (P) Ltd.** Mention the volume you require along with your name and address. OR buy online from www.mtg.in

Add ₹ 90 as postal charges

Older issues can be accessed on **digital.mtg.in** in digital form.

Mail your order to :

Circulation Manager,
 MTG Learning Media (P) Ltd.
 Plot No. 99, Sector 44
 Institutional Area, Gurugram, (HR)
 Tel.: (0124) 6601200
 E-mail: info@mtg.in
 Web: www.mtg.in

buy online at www.mtg.in

JEE 2020 PRACTICE PAPER ADVANCED

Exam on
23rd August

PAPER - I

SECTION 1 (Maximum Marks : 12)

- This section contains FOUR (04) questions.
- Each question has FOUR options. ONLY ONE of these four options is the correct answer.
- For each question, choose the option corresponding to the correct answer.
- Answer to each question will be evaluated according to the following marking scheme :

Full Marks : +3 If ONLY the correct option is chosen.

Zero Marks : 0 If none of the options is chosen (i.e. the question is unanswered).

Negative Marks : -1 In all other cases.

1. A certain dye absorbs light of $\lambda = 4530 \text{ \AA}$ and then fluorescence light of 5080 \AA . Assuming that under given conditions 47% of the absorbed energy is re-emitted out as fluorescence, calculate the ratio of quanta emitted out to the no. of quanta absorbed.
- (a) 0.901 (b) 0.527 (c) 0.725 (d) 1.09

2. KI in acetone, undergoes S_N2 reaction with each P, Q, R and S. The rates of the reaction vary as

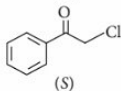

- (a) $P > Q > R > S$ (b) $S > P > R > Q$
 (c) $P > R > Q > S$ (d) $R > P > S > Q$
3. Calculate the amount of polythene formed from 20 kg of calcium carbide from the reactions given below :

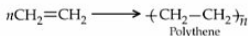

- (a) 28 g (b) 6 g (c) 9 kg (d) 64 kg
4. FeCr_2O_4 (chromite) is converted to Cr by following steps :



I, II and III are

- | I | II | III |
|-------------------------------------------------|------------------------|--------------|
| (a) $\text{Na}_2\text{CO}_3/\text{air}, \Delta$ | C | C |
| (b) $\text{NaOH}/\text{air}, \Delta$ | C, Δ | Al, Δ |
| (c) $\text{NaOH}/\text{air}, \Delta$ | C, Δ | Pb, Δ |
| (d) conc. $\text{H}_2\text{SO}_4, \Delta$ | NH_4Cl | C, Δ |

SECTION 2 (Maximum Marks : 32)

- This section contains EIGHT (08) questions.
- Each question has FOUR options. ONE OR MORE THAN ONE of these four option(s) is(are) correct answer(s).
- For each question, choose the option(s) corresponding to (all) the correct answer(s).
- Answer to each question will be evaluated according to the following marking scheme :

Full Marks : +4 If only (all) the correct option(s) is (are) chosen.

Partial Marks : +3 If all the four options are correct but ONLY three options are chosen.

Partial Marks : +2 If three or more options are correct but ONLY two options are chosen and both of which are correct.

Partial Marks : +1 If two or more options are correct but ONLY one option is chosen and it is a correct option.

Zero Marks : 0 If none of the options is chosen (i.e. the question is unanswered).

Negative Marks : -1 In all other cases.

- For example, in a question, if (a), (b) and (d) are the ONLY three options corresponding to correct answers, then choosing ONLY (a), (b) and (d) will get +4 marks; choosing ONLY (a) and (b) will get +2 marks; choosing ONLY (a) and (d) will get +2 marks; choosing ONLY (b) and (d) will get +2 marks; choosing ONLY (a) will get +1 mark; choosing ONLY (b) will get +1 mark; choosing ONLY (d) will get +1 mark; choosing no option (i.e. the question is unanswered) will get 0 marks; and choosing any other combination of options will get -1 mark.

5. Choose the inappropriate statement(s) regarding the following reaction :

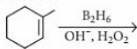

- (a) Syn addition of $-\text{H}$ (from BH_3) and $-\text{OH}$ (from solution) occurs.
 (b) Syn addition of $-\text{H}$ (from BH_3) and $-\text{OH}$ (from H_2O_2) occurs.
 (c) The product is optically active.
 (d) Addition follows anti-Markownikoff's orientation.
6. In a 1^{st} order reaction, amount of the substance left after n half-lives and average life of a 1^{st} order reaction respectively are

(a) $\frac{[A_0]}{2^n}, \frac{1}{k}$ (b) $\frac{[A_0]}{n^2}, \frac{1}{k}$
 (c) $\frac{[A_0]}{2^n}, 1.44 \times t_{1/2}$ (d) $\frac{[A_0]}{n^2}, 1.44 \times t_{1/2}$

7. Which of the following statements are correct?
 (a) Each atom has at least one orbital, symmetrical about the nucleus.
 (b) Each orbit has at least one orbital, symmetrical about the nucleus.
 (c) Number of electrons in Ne having their angular momentum equal to zero are four.
 (d) Number of waves made by an electron in an orbit is equal to number of orbit.
8. KMnO_4 + gas 'B' $\xrightarrow{\quad}$ Aq. suspension of white solid
 H_2O_2 + gas 'B' $\xrightarrow{\quad}$ Aq. suspension of white solid
 Br_2 -water + gas 'B' $\xrightarrow{\quad}$ Aq. suspension of white solid
- $\xrightarrow[\text{P}]{\text{Reagent}}$ H_2SO_4
- Which of the following reagents can be used as 'P'?

- (a) O_3 (b) Excess Cl_2 water
 (c) Conc. HNO_3 (d) HCl

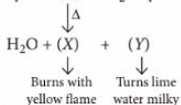

Which of the following reactions will give both gases (X) and (Y)?

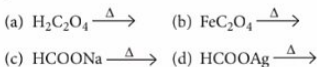

10. Identify the binary mixture(s) that can be separated into individual compounds, by differential extraction, as shown in the given scheme :

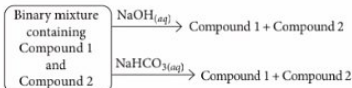

- (a) $\text{C}_6\text{H}_5\text{OH}$ and $\text{C}_6\text{H}_5\text{COOH}$
 (b) $\text{C}_6\text{H}_5\text{COOH}$ and $\text{C}_6\text{H}_5\text{CH}_2\text{OH}$
 (c) $\text{C}_6\text{H}_5\text{CH}_2\text{OH}$ and $\text{C}_6\text{H}_5\text{OH}$
 (d) $\text{C}_6\text{H}_5\text{CH}_2\text{OH}$ and $\text{C}_6\text{H}_5\text{CH}_2\text{COOH}$

11. Which of the following represents the correct order?

- (a) Stability : $\dot{\text{C}}\text{H}_3 < \text{CH}_3 - \dot{\text{C}}\text{H}_2 < \text{CH}_3 - \dot{\text{C}}\text{H} - \text{CH}_3 < (\text{CH}_3)_3\dot{\text{C}}$
 (b) Stability : $\dot{\text{C}}\text{H}_3 < \text{CH}_3 - \dot{\text{C}}\text{H}_2 < \text{CH}_3 - \dot{\text{C}}\text{H} - \text{CH}_3 < (\text{CH}_3)_3\dot{\text{C}}$
 (c) Hyperconjugation : $\text{CH}_3 - <\text{CH}_3 - \text{CH}_2 - < (\text{CH}_3)_2\text{CH} - < (\text{CH}_3)_3\text{C} -$
 (d) Basic nature : $\bar{\text{C}}\text{H}_3 > \bar{\text{N}}\text{H}_2 > \bar{\text{O}}\text{H} > \bar{\text{F}}$

12. If T is the time required by electron in taking one round in an orbit, n represents the number of waves in an orbit, r represents the radius of orbit, then which have the value of $1/2$ for 2^{nd} orbit of H and 4^{th} orbit of He^+ ?

(a) $\frac{r_2(\text{H})}{r_4(\text{He}^+)}$ (b) $\frac{T_2(\text{H})}{T_4(\text{He}^+)}$
 (c) $\frac{n_2(\text{H})}{n_4(\text{He}^+)}$ (d) $\frac{E_2(\text{H})}{E_4(\text{He}^+)}$

SECTION 3 (Maximum Marks : 18)

- This section contains SIX (06) questions. The answer to each question is a NUMERICAL VALUE.
 - For each question, enter the correct numerical value of the answer using the mouse and the on-screen virtual numeric keypad in the place designated to enter the answer. If the numerical value has more than two decimal places, truncate/round-off the value to TWO decimal places.
 - Answer to each question will be evaluated according to the following marking scheme :
Full Marks : +3 If ONLY the correct numerical value is entered.
Zero Marks : 0 In all other cases.
- How many terminal alkynes isomers are possible for the formula C_6H_{10} ?
 - How many of the isomeric ketones having the molecular formula $C_6H_{12}O$ undergo iodoform test?
 - The total number of carboxylic acid groups in the product P is

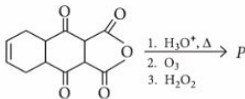

- A tetrapeptide has —COOH group on alanine. This produces glycine (Gly), valine (Val), phenyl alanine (Phe) and alanine (Ala), on complete hydrolysis. For this tetrapeptide, the number of possible sequences (primary structures) with —NH₂ group attached to a chiral center is
- If edge fraction unoccupied in ideal anti-fluorite structure is x . Calculate the value of Z (where, $Z = \frac{x}{0.097}$).
- m -Phenylenediamine when treated with $NaNO_2$ and HCl at $0-5^\circ C$ undergoes self-coupling reaction to produce a trimer, known as Bismarck brown. The total number of nitrogen atoms in the final product is

PAPER - II
SECTION 1 (Maximum Marks : 32)

- This section contains EIGHT (08) questions.
 - Each question has FOUR options. ONE OR MORE THAN ONE of these four option(s) is(are) correct answer(s).
 - For each question, choose the option(s) corresponding to (all) correct answer(s).
 - Answer to each question will be evaluated according to the following marking scheme :
- Full Marks : +4 If only (all) the correct option(s) is (are) chosen.
 - Partial Marks : +3 If all the four options are correct but ONLY three options are chosen.
 - Partial Marks : +2 If three or more options are correct but ONLY two options are chosen and both of which are correct.
 - Partial Marks : +1 If two or more options are correct but ONLY one option is chosen and it is a correct option.
 - Zero Marks : 0 If none of the options is chosen (i.e. the question is unanswered).
 - Negative Marks : -1 In all other cases.
- For example, in a question, if (a), (b) and (d) are the ONLY three options corresponding to correct answers, then choosing ONLY (a), (b) and (d) will get +4 marks; choosing ONLY (a) and (b) will get +2 marks;

- choosing ONLY (a) and (d) will get +2 marks;
 - choosing ONLY (b) and (d) will get +2 marks;
 - choosing ONLY (a) will get +1 mark;
 - choosing ONLY (b) will get +1 mark;
 - choosing ONLY (d) will get +1 mark;
 - choosing no option (i.e. the question is unanswered) will get 0 marks; and
 - choosing any other combination of options will get -1 mark.
- A mixture of two inorganic salts gives following chemical reactivity :
 - Mixture on reaction with dilute H_2SO_4 produces a colourless and unpleasant gas which turns acidified potassium dichromate paper green.
 - Mixture on reaction with concentrated H_2SO_4 gives reddish brown gas which does not produce orange red spots on starch paper.
 - The mixture gives white precipitate with barium chloride solution which is soluble in dilute HCl .
 - The sodium carbonate extract of mixture responds to brown ring test.
 The mixture contains
 - SO_3^{2-} and NO_3^- anions
 - S^{2-} and NO_3^- anions
 - SO_3^{2-} and NO_2^- anions
 - SO_3^{2-} and Br^- anions.

2. From the following data, mark the option(s) where ΔH is correctly written for the given reaction.

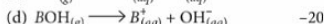
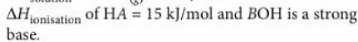
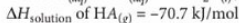
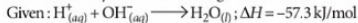

3. The hemiacetal form of glucose is indicated by

- (a) reaction with $(\text{CH}_3\text{CO})_2\text{O}$
 (b) oxidation with Tollens' reagent
 (c) reduction with HI/P
 (d) glycoside formation.

4. $\text{MeCOOEt} \xrightarrow[\text{(iii) OH}^-]{\text{(i) NH}_2\text{NH}_2, \text{(ii) HNO}_2} (\text{B}) \xrightarrow{\text{MeOH}} (\text{C})$

Which of the following statements are correct about the given reactions sequence?

- (a) The compounds (B) and (C), respectively, are $\text{Me}-\text{N}=\text{C}=\text{O}$ and MeNHCOOEt .
 (b) The compounds (B) and (C), respectively, are $\text{Et}-\text{N}=\text{C}=\text{O}$ and MeNH_2 .
 (c) The reaction proceeds via the formation of acyl nitrene (MeCON:) as the intermediate species.
 (d) The reaction proceeds via the formation of acyl nitrene (EtCON:) as the intermediate species.
5. Which of the following substrates will give rearranged product in hydration reaction?

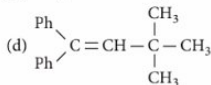
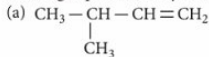

6. Identify compound(s) in which gauche conformer is more stable than staggered.

- (a) 1, 2-Difluoroethane (b) Chloropropane
 (c) Ethylene glycol (d) Succinic acid

7. Which among the following statements is/are correct?

- (a) XeF_4 and SbF_5 combine to form salt.

(b) He and Ne do not form clathrates.

(c) He has lowest b.p.t. in its group.

(d) He diffuses through rubber and polyvinyl chloride.

8. Which statements are correct about lactose?

(a) $(\text{C}_1 - \beta)$ (OH) of glucose is linked with (C_4-OH) of galactose.

(b) $(\text{C}_1 - \beta)$ (OH) of galactose is linked with (C_4-OH) of β -glucose.

(c) It is hydrolysed both by amylase and lactase.

(d) It exhibits mutarotation.

Section 2 (Maximum Marks : 18)

- This section contains SIX (06) questions. The answer to each question is a NUMERICAL VALUE.

- For each question, enter the correct numerical value of the answer using the mouse and the on-screen virtual numeric keypad in the place designated to enter the answer. If the numerical value has more than two decimal places, truncate/round-off the value to TWO decimal places.

- Answer to each question will be evaluated according to the following marking scheme :

- Full Marks : +3 If ONLY the correct numerical value is entered.
- Zero Marks : 0 In all other cases.

9. A 20 mL urea solution of 2% (w/v) is mixed with 80 mL of glucose solution of 4% (w/v) at 300 K. The osmotic pressure of the solution in atm will be _____.

10. A compound of mol. wt. 180 is acetylated to give a compound of mol. wt. 390. The number of amino groups in the initial compound is _____.

11. A decapeptide (mol. wt. 796) on complete hydrolysis gives glycine, alanine and phenylalanine. Glycine contributes 47.0% to the total weight of the hydrolysed products. The number of glycine units present in the decapeptide is _____.

12. When (S)-2-chloropentane reacts with NaOH in 75 per cent ethanol and 25 per cent acetone follows rate law :

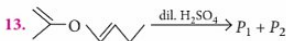

P_1 and P_2 products are identified by

- (a) Tollens' reagent (b) Iodoform test
 (c) $\text{Br}_2 + \text{H}_2\text{O}$ test (d) 1% of alkaline KMnO_4 .

14. Mark the incorrect statement(s).
- Potassium dichromate oxidises a secondary alcohol into a ketone.
 - Potassium permanganate is a weaker oxidising agent than potassium dichromate.
 - Potassium dichromate oxidises a secondary alcohol into aldehyde.
 - Alkaline KMnO_4 solution oxidises tertiary alcohol to a mixture of a ketone and an acid.

SECTION 3 (Maximum Marks : 12)

- This section contains FOUR (04) questions.
- Each question has TWO (02) matching lists: LIST-I and LIST-II.
- FOUR options are given representing matching of elements from LIST-I and LIST-II. ONLY ONE of these four options corresponds to a correct matching.
- For each question, choose the option corresponding to the correct matching.

For each question, marks will be awarded according to the following marking scheme:

Full Marks : +3 If ONLY the option corresponding to the correct matching is chosen.

Zero Marks : 0 If none of the options is chosen (i.e., the question is unanswered).

Negative Marks : -1 In all other cases.

15. Match List-I with List-II.

LIST-I	LIST-II
A. $\text{N}_2(\text{g}) + 3\text{H}_2(\text{g}) \rightleftharpoons 2\text{NH}_3(\text{g}); \Delta H = -ve$	p. K increases with increase in temperature
B. $\text{N}_2(\text{g}) + \text{O}_2(\text{g}) \rightleftharpoons 2\text{NO}(\text{g}); \Delta H = +ve$	q. K decreases with increase in temperature
C. $\text{A}(\text{g}) + \text{B}(\text{g}) \rightleftharpoons 2\text{C}(\text{g}) + \text{D}(\text{g}); \Delta H = +ve$	r. Pressure has no effect
D. $\text{PCl}_5(\text{g}) \rightleftharpoons \text{PCl}_3(\text{g}) + \text{Cl}_2(\text{g}); \Delta H = +ve$	s. Moles of product increase due to addition of inert gas at constant pressure

The correct option is

- $\text{A} \rightarrow \text{p}, \text{s}; \text{B} \rightarrow \text{q}; \text{C} \rightarrow \text{r}; \text{D} \rightarrow \text{q}, \text{s}$
 - $\text{A} \rightarrow \text{q}; \text{B} \rightarrow \text{p}, \text{r}; \text{C} \rightarrow \text{q}, \text{s}; \text{D} \rightarrow \text{p}, \text{s}$
 - $\text{A} \rightarrow \text{p}; \text{B} \rightarrow \text{q}, \text{r}; \text{C} \rightarrow \text{q}, \text{s}; \text{D} \rightarrow \text{s}$
 - $\text{A} \rightarrow \text{q}, \text{r}; \text{B} \rightarrow \text{p}; \text{C} \rightarrow \text{q}, \text{s}; \text{D} \rightarrow \text{p}, \text{r}$
16. Match compounds in List-I with characteristics in List-II.

LIST-I	LIST-II
A. K_2MnO_4	p. Transition element in +6 state
B. KMnO_4	q. Oxidising agent in acidic medium

- C. $\text{K}_2\text{Cr}_2\text{O}_7$ r. Manufactured from pyrolusite ore
 D. K_2CrO_4 s. Manufactured from chromite ore
 The correct option is

- $\text{A} \rightarrow \text{q}, \text{r}; \text{B} \rightarrow \text{s}; \text{C} \rightarrow \text{p}, \text{q}; \text{D} \rightarrow \text{r}, \text{s}$
- $\text{A} \rightarrow \text{r}, \text{s}; \text{B} \rightarrow \text{p}, \text{q}; \text{C} \rightarrow \text{r}, \text{s}; \text{D} \rightarrow \text{q}$
- $\text{A} \rightarrow \text{p}, \text{r}; \text{B} \rightarrow \text{p}, \text{s}; \text{C} \rightarrow \text{q}, \text{s}; \text{D} \rightarrow \text{r}, \text{s}$
- $\text{A} \rightarrow \text{p}, \text{r}; \text{B} \rightarrow \text{q}, \text{r}; \text{C} \rightarrow \text{p}, \text{q}, \text{s}; \text{D} \rightarrow \text{p}, \text{s}$

17. Match the compound in List-I with their common name in List-II.

LIST-I	LIST-II
A. $\text{HOCH}_2(\text{CHOH})_4\text{CH}_2\text{OH}$	p. Oil of mirbane
B. $(\text{H}_2\text{N})_2\text{C}=\text{NH}$	q. Carboic acid
C. $\text{C}_6\text{H}_5\text{OH}$	r. Sorbitol
D. $\text{C}_6\text{H}_5\text{NO}_2$	s. Guanidine

The correct option is

- $\text{A} \rightarrow \text{q}; \text{B} \rightarrow \text{r}; \text{C} \rightarrow \text{p}; \text{D} \rightarrow \text{s}$
- $\text{A} \rightarrow \text{s}; \text{B} \rightarrow \text{p}; \text{C} \rightarrow \text{r}; \text{D} \rightarrow \text{q}$
- $\text{A} \rightarrow \text{r}; \text{B} \rightarrow \text{s}; \text{C} \rightarrow \text{q}; \text{D} \rightarrow \text{p}$
- $\text{A} \rightarrow \text{p}; \text{B} \rightarrow \text{q}; \text{C} \rightarrow \text{r}; \text{D} \rightarrow \text{s}$

18. Match the reaction in List-I with their name/process in List-II.

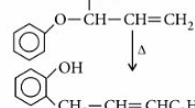
LIST-I	LIST-II
A. $\text{CH}_3 - \text{O}^- + \text{CH}_3 - \text{CH}_2\text{X} \longrightarrow \text{CH}_3\text{OC}_2\text{H}_5$	p. Oxidation
B. $\text{C}_2\text{H}_5 - \text{O} - \text{CH} - \text{CH} = \text{CH}_2$ 	q. Williamson's synthesis
C. $2\text{CH}_3\text{CH}_2\text{OH} + \text{H}_2\text{SO}_4 \xrightarrow{\Delta} \text{CH}_3\text{CH}_2\text{OCH}_2\text{CH}_3$	r. Dehydration
D. $(\text{CH}_3)_2\text{O} + \text{O}_2 \longrightarrow (\text{CH}_2\text{OOH})\text{OCH}_3$	s. Claisen rearrangement

The correct option is

- $\text{A} \rightarrow \text{s}; \text{B} \rightarrow \text{p}; \text{C} \rightarrow \text{r}; \text{D} \rightarrow \text{q}$
- $\text{A} \rightarrow \text{q}; \text{B} \rightarrow \text{s}; \text{C} \rightarrow \text{r}; \text{D} \rightarrow \text{p}$
- $\text{A} \rightarrow \text{r}; \text{B} \rightarrow \text{p}; \text{C} \rightarrow \text{q}; \text{D} \rightarrow \text{s}$
- $\text{A} \rightarrow \text{p}; \text{B} \rightarrow \text{r}; \text{C} \rightarrow \text{s}; \text{D} \rightarrow \text{q}$



BUY ONLINE

Now you can buy

MTG Books & Magazines

Log on to : www.mtg.in

PAPER - I

$$1. (b): E \text{ of light absorbed in one photon} = \frac{hc}{\lambda_{\text{absorbed}}}$$

Let n_1 photons are absorbed, therefore,

$$\text{Total energy absorbed} = \frac{n_1 hc}{\lambda_{\text{absorbed}}}$$

Now, E of light re-emitted out in one photon

$$= \frac{hc}{\lambda_{\text{emitted}}}$$

Let n_2 photons are re-emitted then,

$$\text{Total energy re-emitted out} = n_2 \times \frac{hc}{\lambda_{\text{emitted}}}$$

$$\text{As given, } E_{\text{absorbed}} \times \frac{47}{100} = E_{\text{re-emitted}}$$

$$\frac{hc}{\lambda_{\text{absorbed}}} \times n_1 \times \frac{47}{100} = n_2 \times \frac{hc}{\lambda_{\text{emitted}}}$$

$$\therefore \frac{n_2}{n_1} = \frac{47}{100} \times \frac{\lambda_{\text{emitted}}}{\lambda_{\text{absorbed}}} = \frac{47}{100} \times \frac{5080}{4530}$$

$$\therefore \frac{n_2}{n_1} = 0.527$$

2. (b): $-I$ effect at α carbon (carbon attached to leaving group) will be exerted by  hence (S) will be most reactive.

3. (c): Molecular mass of $\text{CaC}_2 = 40 + 24 = 64$

64 kg of CaC_2 gives = 28 kg of ethene

20 kg of CaC_2 will give = $\frac{28}{64} \times 20 = 8.75$ kg
= 9 kg polythene

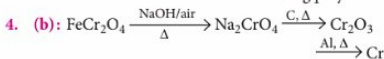

5. (a, c): $-\text{OH}$ comes from H_2O_2 ,

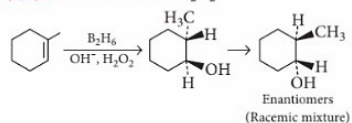

6. (a, c): Amount of the substance left after one half-life = $\frac{[A_0]}{2}$

$$\begin{aligned} \text{Amount of the substance left after two half-lives} \\ = \frac{1}{2} \times \frac{[A_0]}{2} = \frac{[A_0]}{2^2} \end{aligned}$$

Amount of substance left after three half-lives

$$= \frac{1}{2} \times \frac{[A_0]}{2^2} = \frac{[A_0]}{2^3}$$

$$\text{Amount of the substance left after } n \text{ half-lives} = \frac{[A_0]}{2^n}$$

$$\text{and avg. life } (\tau) = \frac{1}{k} = \frac{t_{1/2}}{0.693} = 1.44 \times t_{1/2}$$

7. (a, b, c, d),

8. (a, b, c): O_3 , Cl_2 water and conc. HNO_3 being strong oxidants will oxidise sulphur (present in aq. suspension of white solid) into H_2SO_4 .

9. (a, b): $\text{Na}_2\text{C}_2\text{O}_4 + \text{H}_2\text{SO}_4 \longrightarrow \text{H}_2\text{C}_2\text{O}_4 + \text{Na}_2\text{SO}_4$

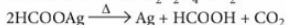
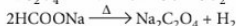
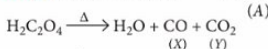

10. (b, d):

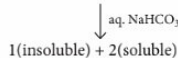
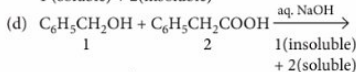
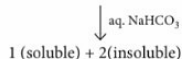
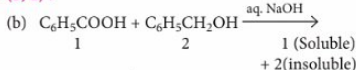

11. (a, b, c, d)

12. (a, b, c): $r_n = r_1 \times n^2/Z$

$$r_{2(\text{H})} = r_{1(\text{H})} \times 2^2 = 4r_{1(\text{H})}$$

$$r_{4(\text{He}^+)} = \frac{r_{1(\text{H})} \times 4^2}{Z} = \frac{r_{1(\text{H})} \times 4^2}{2}$$

$$\therefore \frac{r_{2(\text{H})}}{r_{4\text{He}^+}} = \frac{1}{2}$$

$$T = \frac{2\pi r}{nh} \times 2\pi r m = \frac{4\pi^2 m r^2}{nh}$$

$$T = \frac{n^3}{Z^2} T_{(\text{H})} \quad \left(\because r \propto \frac{n^2}{Z} \right)$$

$$T_{2(\text{H})} = \frac{(2)^3}{(1)^2} T_{(\text{H})} = 8T_{(\text{H})}$$

$$T_{4(\text{He}^+)} = \frac{(4)^3}{(2)^2} T_{(\text{H})} = 16T_{(\text{H})}$$

$$\frac{T_{2(\text{H})}}{T_{4(\text{He}^+)}} = \frac{1}{2}$$

No. of waves in an orbit = No. of orbit

$$\therefore \frac{n_{2H}}{n_{4He^+}} = \frac{2}{4} = \frac{1}{2}$$

$$E_n = \frac{E_1}{n^2} \times Z^2 \Rightarrow E_{2(H)} = \frac{E_1}{4} \times 1^2$$

$$E_{4(He^+)} = \frac{E_1 \times 2^2}{4^2} \therefore \frac{E_{2(H)}}{E_{4(He^+)}} = 1$$

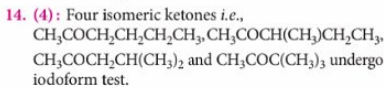
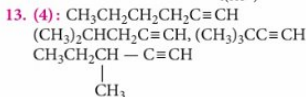

15. (2):

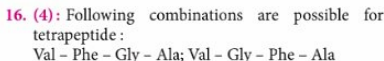
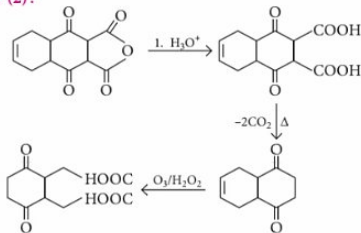

Phe - Gly - Val - Ala; Phe - Val - Gly - Ala

- In all above sequence C-terminal is alanine.
- Glycine is optically inactive amino acid, hence it should not be N-terminal so, only above combination are possible.

17. (3): Fraction of edge unoccupied (x) = $\frac{a-2r}{a}$

$$a = 2\sqrt{2}r, x = \frac{2(\sqrt{2}-1)}{2\sqrt{2}} = \frac{0.414}{1.414} = 0.293$$

$$Z = \frac{x}{0.097} = \frac{0.293}{0.097} = 3$$

18. (8):

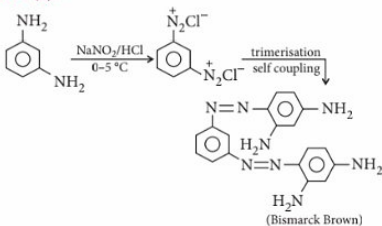

PAPER - II

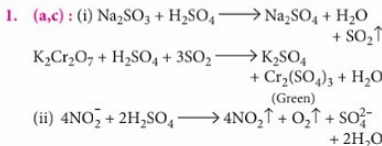

mtg

How can history help to succeed in JEE!

42 Years
 Chapterwise
 Solutions are
 also available
 for each subject
 separately.



₹ 450

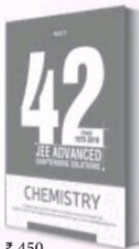

₹ 450



₹ 450

Visit www.mtg.in to buy online!

As it does not produce orange red spots on starch paper, it cannot be Br_2 . So, the anion is NO_3^- .

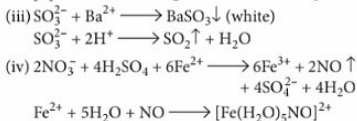

2. (a, b, c): (a) $\Delta_r H = 15 - 57.3 = -42.3 \text{ kJ/mol}$

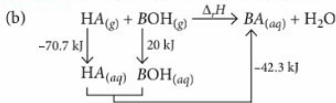

$\Delta_r H = -70.7 + 20 - 42.3 = -93 \text{ kJ/mol}$

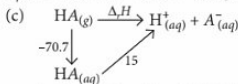

$\Delta_r H = -70.7 + 15 = -55.7 \text{ kJ/mol}$

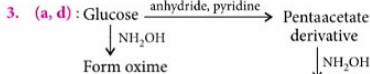
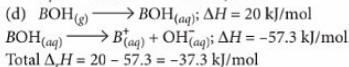

Confirms cyclic structure

Glycoside is functionally acetal which is formed from hemiacetal.

4. (a, c): It is an example of Lossen rearrangement reaction.

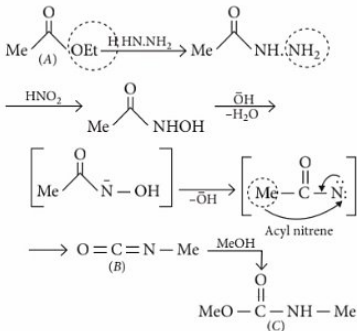

5. (a):

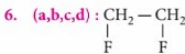
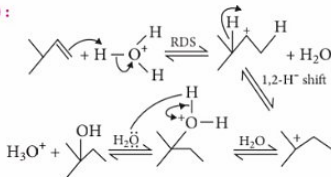

Delocalisation of bond-pair σ of C-H bond in parallel ABMO of C-F is possible; leads to stability in gauche form

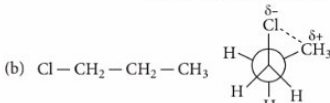

Due to +I nature of $-\text{CH}_3$, δ^+ created on it while -I nature of $-\text{Cl}$ induce δ^- on it. Thus, dipole-dipole interaction leads to stability of gauche conformation.

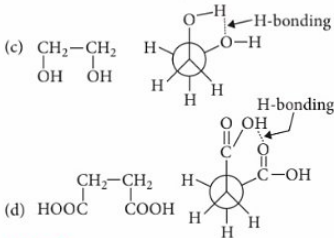

7. (a, b, c, d)

8. (b, d): Amylase hydrolyses α -linkage. It exhibits mutarotation, since in β -D-glucose C-1 (OH) group is hemiacetalic.

9. (6.02): $\therefore \pi = \frac{w}{MV} RT$

$$= \left[\left(\frac{w}{M} \right)_{\text{urea}} + \left(\frac{w}{M} \right)_{\text{glucose}} \right] \times \frac{RT}{V}$$

Now, w_{urea} in 20 mL = $\frac{2 \times 20}{100} = 0.4 \text{ g}$

w_{glucose} in 80 mL = $\frac{4 \times 80}{100} = 3.2 \text{ g}$

$$\therefore \pi = \left[\frac{0.4}{60} + \frac{3.2}{180} \right] \times \frac{0.0821 \times 300 \times 1000}{100}$$

$$\left(\because V = 20 + 80 = 100 \text{ mL} = \frac{100}{1000} \text{ L} \right)$$

$$\pi = 6.02 \text{ atm}$$

10. (5) : Difference in mass of compounds

$$= 390 - 180 = 210$$

Weight of $\text{CH}_3\text{CO}-$ group = 43

Replacement of $-\text{H}$ by $-\text{COCH}_3$ group will cause increase of 42 in mass.

$$\text{Therefore, no. of } -\text{NH}_2 \text{ groups} = \frac{210}{42} = 5$$

11. (6) : $\sim \text{G} - \text{CO} - \text{NH} - \text{A} - \text{CO} - \text{NH} - \text{P} \sim$
Decapeptide

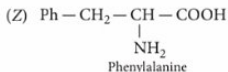
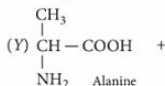
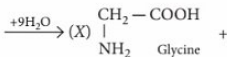

Total wt. of amino acids after addition of 9 mole of

$$\text{H}_2\text{O} = 796 + 9 \times 18 = 958$$

Since contribution of glycine is 47%.

$$\therefore \text{Total mass of glycine} = 958 \times 0.47 \approx 450$$

Molar mass of glycine = 75

$$\text{Therefore, no. of glycine molecules} = 450/75 = 6$$

$$12. (8) : \% \text{S}_\text{N}1 = \frac{3 \times 10^{-6} [\text{substrate}]}{2.35 \times 10^{-5} [\text{subs.}] \times 1.5 + 3 \times 10^{-6} [\text{subs.}]} \times 100$$

$$= 7.824 \approx 8$$

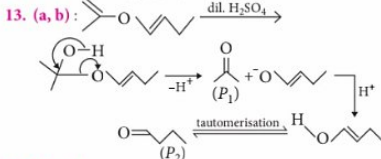

14. (b, c, d) : In acidic medium, KMnO_4 gives 5 oxygen while acidic $\text{K}_2\text{Cr}_2\text{O}_7$ gives 3 oxygen and secondary alcohols are oxidised to ketones.

Tertiary alcohols are resistance to oxidation in neutral or alkaline KMnO_4 solution but are readily oxidised in acidic solution ($\text{KMnO}_4/\text{H}_2\text{SO}_4$) to a mixture of a ketone and an acid each contains lesser number of carbon atoms than the original alcohol.

15. (b)

16. (d)

17. (c) : (A) $\text{HOCH}_2(\text{CHOH})_4\text{CH}_2\text{OH}$
Sorbitol

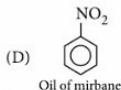
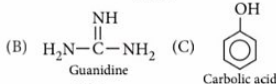

18. (b)

mtg

Master Resource Books in Chemistry

Key Features

- Concise theory for competitive exams
- Illustrations with detailed solutions
- Twists and turns to learn important formulae
- Elaborate solutions to mysterious NCERT problems
- Practice assignments with pinch of hints
- Solved MCQs single and multiple option correct type, Assertion & Reason, Fill in the blanks, True or False, Comprehension, Integer & Matching types with Miscellaneous Questions



₹ 700



₹ 350



₹ 750



₹ 350

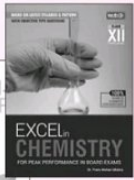

₹ 550

Visit www.mtg.in to buyonline!

Titration has wide applications in food industry, medical field as well as in automotive industry. In medical, it is used to determine proper concentration of anaesthetics and to measure glucose level in the blood. In automotive, it is used during production of biodiesel fuel.

Weak acid-Weak base

In the titration of CH_3COOH with NH_4OH the pH at the equivalence point lies between 6.5-7.5 but no sharp change in pH is observed in these titrations. Thus, no simple indicator can be used for the detection of the equivalence point.

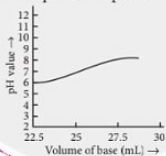

Strong acid-Strong base

In the titration of HCl with NaOH , the equivalence point lies in the pH range of 4-10. Thus, methyl orange (pH range 3.2-4.5), methyl red (pH range 4.2-6.3) and phenolphthalein (pH range 8.3-10) will be the suitable indicators.

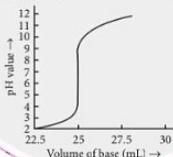

Titration Curves

Weak acid-Strong base

In the titration of CH_3COOH with NaOH , the equivalence point lies between the pH range 7.5-10. Hence, phenolphthalein (pH range 8.3-10) will be the suitable indicator.

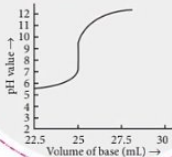

Strong acid-Weak base

In the titration of HCl with NH_4OH , the pH at equivalence point lies between the pH range 4-6.5. Thus, methyl orange (pH range 3.1-4.4) or methyl red (pH range 4.2-6.3) will be the suitable indicators.

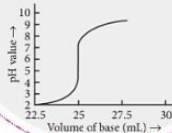

Important Terms

- **Titration** is the measurement of the volume of a solution of one reactant that is required to react completely with a measured amount of another reactant.
- The solution which is to be titrated is called **titrate**.
- The solution with which the titration is to be done is called the **titrant**.
- The substance usually added into the solution taken in the titration flask to detect the equivalence point is called an **indicator**. The **equivalence point** is the ideal point for the completion of titration, i.e., it is the exact point in a titration when moles of one titrant becomes equal to the moles of the substance being titrated.
- The **end point** is the point at which the indicator just changes its colour. End point indicates that equivalence point has been reached.
- The point at which there is a sudden change in pH when a very small amount of the titrant is added to the titrate is called **point of inflection**.
- The curve between pH values of the solution and the volume of titrant added as the titration proceeds is called a **titration curve**.
- The determination of concentration of bases by titration with a standard acid is called **acidimetry**.
- The determination of concentration of acids by titration with a standard base is called **alkalimetry**.

Types of Indicators

- **Self indicator**: A substance is said to be self indicator if it itself acts as an indicator in titration e.g., potassium permanganate (KMnO_4) and oxalic acid (COOH)₂.
- **External indicator**: In some redox titrations, the end point is detected with the help of a substance which is not added to the solution being titrated but used outside the titrating system, e.g., potassium ferricyanide.
- **Internal indicator**: The substance or reagents which are added to the solution in the conical flask or beaker during the titration to find out the end point, e.g., phenolphthalein, methyl orange, starch solution, etc.

EXTRACTION OF SOME METALS

Technological development for extraction of metals from low grade ores is an emerging and important area due to depletion of high grade ore resources. Hydrometallurgy, in principle, can provide viable technical options for processing lean ores.

CONCEPT
MAP

Class
XII

Iron (Fe) (Pig iron)

- **Concentration:** The crushed ore is concentrated by gravity separation and froth floatation process (for sulphide ores).
- **Calcination:** Ore is heated strongly in the presence of a limited supply of air in a reverberatory furnace. Sulphide ores are roasted to their oxides.
- **Smelting:** Calcined ore is smelted in a blast furnace.

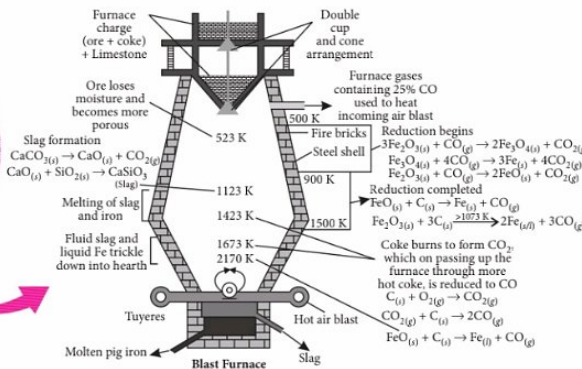

Sodium (Na) (Down's process)

- The oxides of highly electropositive metals like Na, K, Mg, Al requires very high temperature for reduction.
- These metals are extracted by the electrolysis of their oxides, hydroxides or chlorides in fused state.
- A small amount of some other salt is added to lower the fusion temperature or to increase the conductivity or both.
- Electrolysis of fused mixture of NaCl and CaCl₂:

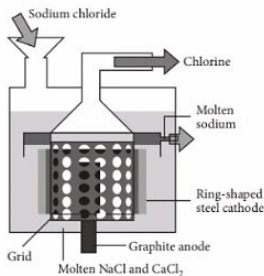
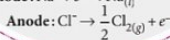
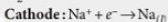

Aluminium (Al) (Hall - Heroult process)

- Process of obtaining aluminium by electrolysis of a mixture of purified alumina, cryolite and fluorspar. Purified alumina is obtained by calcination of bauxite ore (Al₂O₃·xH₂O).

Electrolytic reactions involved:

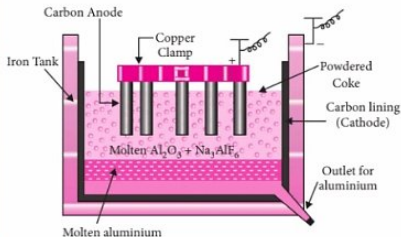
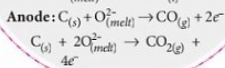
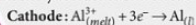

1. Which of the following reactions show the reducing property of hydrochloric acid?
- $\text{ZnCO}_3 + 2\text{HCl} \rightarrow \text{ZnCl}_2 + \text{H}_2\text{O} + \text{CO}_2$
 - $\text{Mg} + 2\text{HCl} \rightarrow \text{MgCl}_2 + \text{H}_2$
 - $\text{MnO}_2 + 4\text{HCl} \rightarrow \text{MnCl}_2 + 2\text{H}_2\text{O} + \text{Cl}_2$
 - $\text{NH}_4\text{OH} + \text{HCl} \rightarrow \text{NH}_4\text{Cl} + \text{H}_2\text{O}$
2. Reduction potentials of some ions are given below. Arrange them in decreasing order of oxidising power.
- | Ion | ClO_4^- | IO_4^- | BrO_4^- |
|-----------------------------------|------------------|-----------------|------------------|
| Reduction potential (E°) | 1.19 V | 1.65 V | 1.74 V |
- $\text{ClO}_4^- > \text{IO}_4^- > \text{BrO}_4^-$
 - $\text{IO}_4^- > \text{BrO}_4^- > \text{ClO}_4^-$
 - $\text{BrO}_4^- > \text{IO}_4^- > \text{ClO}_4^-$
 - $\text{BrO}_4^- > \text{ClO}_4^- > \text{IO}_4^-$
3. Which of the following will not give iodoform test?
- n*-Butyl alcohol
 - sec*-Butyl alcohol
 - Acetophenone
 - Acetaldehyde
4. Energy of an electron in hydrogen atom is given by $E = -\frac{13.6}{n^2}$ eV. Which one of the following statements is true if n is changed from 1 to 3? Energy will
- decrease three times
 - increase three times
 - increase nine times
 - decrease nine times.
5. In the coagulation of a positive sol, the flocculation powers of Cl^- , SO_4^{2-} , PO_4^{3-} and $[\text{Fe}(\text{CN})_6]^{4-}$ are in the order
- $\text{Cl}^- > \text{SO}_4^{2-} > [\text{Fe}(\text{CN})_6]^{4-} > \text{PO}_4^{3-}$
 - $\text{Cl}^- > \text{PO}_4^{3-} > \text{SO}_4^{2-} > [\text{Fe}(\text{CN})_6]^{4-}$
 - $[\text{Fe}(\text{CN})_6]^{4-} > \text{PO}_4^{3-} > \text{SO}_4^{2-} > \text{Cl}^-$
 - $\text{Cl}^- > \text{SO}_4^{2-} > \text{PO}_4^{3-} > [\text{Fe}(\text{CN})_6]^{4-}$
6. Which of the following complexes formed by Cu^{2+} ions is most stable?
- $\text{Cu}^{2+} + 4\text{NH}_3 \rightleftharpoons [\text{Cu}(\text{NH}_3)_4]^{2+}$; $\log K = 11.6$
 - $\text{Cu}^{2+} + 4\text{CN}^- \rightleftharpoons [\text{Cu}(\text{CN})_4]^{2-}$; $\log K = 27.3$
 - $\text{Cu}^{2+} + 2\text{en} \rightleftharpoons [\text{Cu}(\text{en})_2]^{2+}$; $\log K = 15.4$
 - $\text{Cu}^{2+} + 4\text{H}_2\text{O} \rightleftharpoons [\text{Cu}(\text{H}_2\text{O})_4]^{2+}$; $\log K = 8.9$
7. The correct decreasing order of acidic character is
- $\text{HClO} > \text{HBrO} > \text{HIO}$
 - $\text{HIO} > \text{HBrO} > \text{HClO}$
 - $\text{HBrO} > \text{HIO} > \text{HClO}$
 - $\text{HClO} > \text{HIO} > \text{HBrO}$
8. Cellulose, the most important constituent of plant cell wall, is made up of
- branched chain of glucose molecules linked by α (1 \rightarrow 6) glycosidic bonds at the site of branching
 - unbranched chain of glucose molecules linked by α (1 \rightarrow 4) glycosidic bonds
 - branched chain of glucose molecules linked by β (1 \rightarrow 4) glycosidic bond in straight chain and α (1 \rightarrow 6) glycosidic bond at the site of branching
 - unbranched chain of glucose molecules linked by β (1 \rightarrow 4) glycosidic bonds.
9. 1.020 g of metallic oxide contains 0.540 g of the metal. If the specific heat of the metal, M is $0.216 \text{ cal deg}^{-1}\text{g}^{-1}$, the molecular formula of its oxide is
- MO
 - M_2O_3
 - M_2O_4
 - M_2O
10. The most stable conformation of chlorocyclohexane at room temperature is

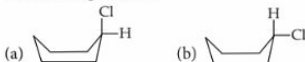

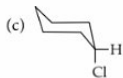

11. Identify the correct statement for change in Gibbs' energy for a system (ΔG_{system}) at constant temperature and pressure.

- (a) If $\Delta G_{system} = 0$, the system has attained equilibrium.
 (b) If $\Delta G_{system} = 0$, the system is still moving in a particular direction.
 (c) If $\Delta G_{system} = 0$, the process is not spontaneous.
 (d) If $\Delta G_{system} = 0$, the process is spontaneous.

12. The emf of the three galvanic cells given below are represented by E_1 , E_2 and E_3 .

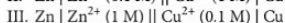
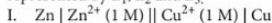

Which of the following is true?

- (a) $E_1 > E_2 > E_3$ (b) $E_3 > E_2 > E_1$
 (c) $E_3 > E_1 > E_2$ (d) $E_2 > E_1 > E_3$
13. 1500 mL flask contains 400 mg O_2 and 60 mg H_2 at $100^\circ C$. What is the total pressure in the flask?
 (a) 0.66 atm (b) 0.867 atm
 (c) 8.67 atm (d) 13.47 atm

14. Which of the following does not represent the correct order of the property indicated?

- (a) $Sc^{3+} > Cr^{3+} > Fe^{3+} > Mn^{3+}$: Ionic radii
 (b) $Sc < Ti < Cr < Mn$: Density
 (c) $Mn^{2+} > Ni^{2+} < Co^{2+} < Fe^{2+}$: Ionic radii
 (d) $FeO < CaO > MnO > CuO$: Basic nature

15. A red coloured oxide (X) on treatment with conc. HNO_3 gives a compound (Y). (Y) with HCl produces a chloride (Z) which is insoluble in cold water but soluble in hot water. (Z) can also be formed by treating (X) with conc. HCl. Compounds X, Y and Z are

- (a) Pb_3O_4 , PbO_2 , $PbCl_2$
 (b) Mn_3O_4 , MnO_2 , $MnCl_2$
 (c) Fe_3O_4 , Fe_2O_3 , $FeCl_3$
 (d) Fe_3O_4 , FeO , $FeCl_2$

16. Which is not true about the coordination compound $[Co(en)_2Cl_2]Cl$?

- (a) It exhibits geometrical isomerism.
 (b) It exhibits optical isomerism.
 (c) It exhibits ionisation isomerism.
 (d) It is an octahedral complex.

17. Polarity in a molecule and hence, the dipole moment depends primarily on electronegativity of the constituent atoms and shape of a molecule. Which of the following has the highest dipole moment?

- (a) CO_2 (b) HI (c) H_2O (d) SO_2
18. The rapid change of pH near the stoichiometric point of an acid-base titration is the basis of indicator detection. pH of the solution is related to the ratio of the concentration of conjugate acid (HIn) and base (In^-) forms of the indicator by the expression

(a) $\log \frac{[In^-]}{[HIn]} = pK_a + pH$

(b) $\log \frac{[HIn]}{[In^-]} = K_a + pH$

(c) $\log \frac{[HIn]}{[In^-]} = pH - pK_a$

(d) $\log \frac{[In^-]}{[HIn]} = pH - pK_a$

19. Correct set of four quantum numbers for the valence (outermost) electron of rubidium ($Z = 37$) is

(a) 5, 0, 0, $+\frac{1}{2}$ (b) 5, 1, 0, $+\frac{1}{2}$

(c) 5, 1, 1, $+\frac{1}{2}$ (d) 6, 0, 0, $+\frac{1}{2}$

20. If $K_{sp}[AgCNS] = 1 \times 10^{-12}$ and $K_{sp}[AgBr] = 5 \times 10^{-13}$ then the value of simultaneous solubility of AgCNS and AgBr in a solution of water will be

- (a) 8.16×10^{-7} , 4.08×10^{-7}
 (b) 4.08×10^{-7} , 8.16×10^{-7}
 (c) 8.16, 4.08
 (d) 1×10^{-12} , 5×10^{-13}

21. Which of the following reactions depicts the oxidising property of SO_2 ?

- (a) $SO_2 + H_2O \rightarrow H_2SO_3$
 (b) $2H_2S + SO_2 \rightarrow 3S + 2H_2O$
 (c) $Cl_2 + SO_2 \rightarrow SO_2Cl_2$
 (d) $2MnCl_4 + 5SO_2 + 2H_2O \rightarrow 5SO_4^{2-} + 2Mn^{2+} + 4H^+$

22. 500 mL of a hydrocarbon gas burnt in excess of oxygen yielded 2500 mL of CO_2 and 3.0 L of water vapour. The formula of the hydrocarbon is

- (a) C_5H_{12} (b) CH_4 (c) C_2H_4 (d) C_3H_6

23. The compound in which carbon uses only sp^3 -hybrid orbitals for bond formation is

- (a) $(CH_3)_3C-CHO$ (b) $(CH_3)_3C-OH$
 (c) NH_2CONH_2 (d) $HCOOH$

FULLY LOADED & COMPLETELY UPDATED

MTG's BITSAT Power Guide is not only the most exhaustive prep-tool, but also the only book available at present, updated as per the latest BITSAT syllabus for students aspiring for top rank in BITSAT 2020.



Attempt all questions
from this book on the
Web + Mobile for
free

(For details see inside the book)

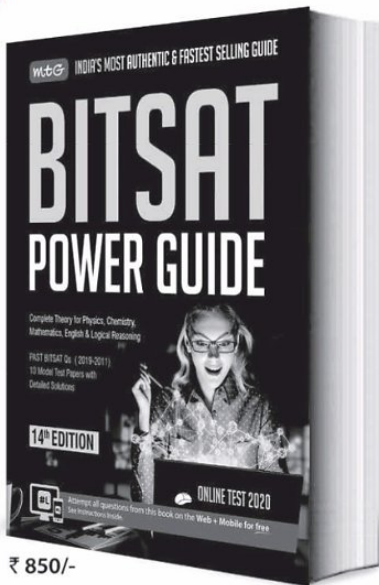

₹ 850/-

Get MTG's BITSAT Power Guide today for a real-world feel of BITSAT. Find out what's different about the BITSAT test, including its pattern of examination and key success factors. Be it with chapterwise MCQs or model test papers, check how good your chances are for glory in BITSAT 2020.

FEATURES

- Covers all 5 subjects - Physics, Chemistry, Mathematics, English & Logical Reasoning
- Chapterwise MCQs in each section for practice
- Past chapterwise BITSAT Qs (2019-2011)
- 10 Model Test Papers with detailed solutions
- Attempt all questions & tests from this book online, for free with #L

Visit www.MTG.in to buy online. Or visit a leading bookseller near you.
For more information, email info@mtg.in or call **1800-10-38673** (toll-free).

24. Which among the following is aromatic?



25. RCH_2CH_2OH can be converted to RCH_2CH_2COOH by the following sequence of reagents.

- (a) PBr_3, KCN, H_3O^+ (b) $PBr_3, KCN, H_2/Pt$
 (c) KCN, H_3O^+ (d) HCN, PBr_3, H_3O^+

26. Which of the following statements is not true?

- (a) London smog is a mixture of smoke and fog.
 (b) London smog is oxidising in nature.
 (c) Photochemical smog causes irritation in eyes.
 (d) Photochemical smog results in the formation of PAN.

27. An element with molar mass $2.7 \times 10^{-2} \text{ kg mol}^{-1}$ forms a cubic unit cell with edge length 405 pm. If its density is $2.7 \times 10^3 \text{ kg m}^{-3}$, what is the nature of the cubic unit cell?

- (a) Simple cubic (b) Face-centred
 (c) Body-centred (d) End-centred

28. The ease of dehydrohalogenation with alcoholic KOH in case of 1-Chloroethane (I), 2-Chloropropane (II) and 2-Chloro-2-methylpropane (III) is of the order

- (a) III > II > I (b) I > II > III
 (c) II > I > III (d) I > III > II

29. The correct order of reactivity towards electrophilic substitution is

- (a) benzene > phenol > benzoic acid > chlorobenzene
 (b) phenol > benzene > chlorobenzene > benzoic acid
 (c) chlorobenzene > benzoic acid > phenol > benzene
 (d) benzoic acid > chlorobenzene > benzene > phenol.

30. For a reaction, $2K_{(g)} + L_{(g)} \rightarrow 2M_{(g)}$; $\Delta U^\circ = -10.5 \text{ kJ}$ and $\Delta S^\circ = -44.1 \text{ J K}^{-1}$. Calculate ΔG° for the reaction and predict whether the reaction will be spontaneous or non-spontaneous?

- (a) $\Delta G^\circ = +0.16 \text{ kJ}$, non-spontaneous
 (b) $\Delta G^\circ = -0.16 \text{ kJ}$, spontaneous
 (c) $\Delta G^\circ = +26.12 \text{ kJ}$, non-spontaneous
 (d) $\Delta G^\circ = -26.12 \text{ kJ}$, spontaneous

31. The vapour pressure of benzene at a certain temperature is 640 mm of Hg. A non-volatile and non-electrolyte solid weighing 2.175 g is added to 39.08 g of benzene. The vapour pressure of the solution is 600 mm of Hg. What is the molecular weight of solid substance?

- (a) 59.5 g mol^{-1} (b) 69.5 g mol^{-1}
 (c) 79.6 g mol^{-1} (d) 79.9 g mol^{-1}

32. The two isomers X and Y with the formula $Cr(H_2O)_5ClBr_2$ were taken for experiment on depression in freezing point. It was found that one mole of X gave depression corresponding to 2 moles of particles and one mole of Y gave depression due to 3 moles of particles. The structural formulae of X and Y respectively are

- (a) $[Cr(H_2O)_5Cl]Br_2$; $[Cr(H_2O)_4Br_2]Cl \cdot H_2O$
 (b) $[Cr(H_2O)_5Cl]Br_2$; $[Cr(H_2O)_3ClBr_2] \cdot 2 H_2O$
 (c) $[Cr(H_2O)_5Br]BrCl$; $[Cr(H_2O)_4ClBr]Br \cdot H_2O$
 (d) $[Cr(H_2O)_4Br_2]Cl \cdot H_2O$; $[Cr(H_2O)_5Cl]Br_2$

33. The correct order of basicities of the following compounds is

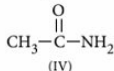
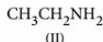
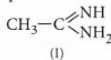

- (a) II > I > III > IV (b) I > III > II > IV
 (c) III > I > II > IV (d) I > II > III > IV

34. In complex hydrides, hydride ions act as ligand and are coordinated to metal ions. These hydrides are good reducing agents. Which of the following hydrides is not a complex hydride?

- (a) $LiAlH_4$ (b) $NaBH_4$
 (c) $(AlH_3)_n$ (d) $LiBH_4$

35. Match the column I with column II and mark the appropriate choice.

	Column I (Property)	Column II (Metal)
(A)	Element with highest second ionisation enthalpy	(i) Cr
(B)	Element with highest third ionisation enthalpy	(ii) Cu
(C)	M in $M(CO)_6$ is	(iii) Zn
(D)	Element with highest heat of atomisation	(iv) Ni

- (a) (A) → (ii), (B) → (iii), (C) → (i), (D) → (iv)
 (b) (A) → (iv), (B) → (iii), (C) → (i), (D) → (ii)
 (c) (A) → (iii), (B) → (i), (C) → (ii), (D) → (iv)
 (d) (A) → (i), (B) → (ii), (C) → (iii), (D) → (iv)

36. The Diels-Alder reaction between 1,3-cyclohexadiene and acrylonitrile gives the adduct,



Its IUPAC name is

- (a) bicyclo [2.2.2] oct-2-en-5-nitrile
 (b) bicyclo [2.2.2] oct-5-en-2-carbonitrile
 (c) 3-cyano bicyclo [2.2.2] oct-5-ene
 (d) 2-cyano bicyclo [2.2.2] oct-5-ene.
37. Give the decreasing order of reactivities of the following monomers towards cationic addition polymerisation.
- I. $\text{MeCH}=\text{CH}_2$ II. $\text{PhCH}=\text{CH}_2$
 III. $\text{CH}_2=\text{CH}-\text{COOMe}$ IV. $\text{CH}_2=\text{CH}-\text{Cl}$
- (a) I > II > III > IV (b) II > I > IV > III
 (c) II > I > III > IV (d) I > II > IV > III

38. For which of the following amino acids, van-Slyke estimation method is not applicable?
 (a) Alanine (b) Aspartic acid
 (c) Serine (d) Proline

39. The appropriate reagent for the transformation

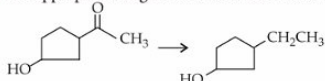

- (a) Zn-Hg, HCl (b) $\text{NH}_2\text{NH}_2, \text{OH}^-$
 (c) H_2/Ni (d) NaBH_4
40. Which of the following sets of reactants is used for the preparation of paracetamol from phenol?
 (a) $\text{HNO}_3, \text{H}_2/\text{Pd}, (\text{CH}_3\text{CO})_2\text{O}$
 (b) $\text{H}_2\text{SO}_4, \text{H}_2/\text{Pd}, (\text{CH}_3\text{CO})_2\text{O}$
 (c) $\text{C}_6\text{H}_5\text{N}_2\text{Cl}, \text{SnCl}_2/\text{HCl}, (\text{CH}_3\text{CO})_2\text{O}$
 (d) $\text{Br}_2/\text{H}_2\text{O}, \text{Zn}/\text{HCl}, (\text{CH}_3\text{CO})_2\text{O}$

SOLUTIONS

1. (c): HCl is oxidised by strong oxidising agents like manganese dioxide, lead dioxide, potassium permanganate, potassium dichromate, etc. hence, acts as a reducing agent.
 $\text{MnO}_2 + 4\text{HCl} \rightarrow \text{MnCl}_2 + 2\text{H}_2\text{O} + \text{Cl}_2$
2. (c): Higher the reduction potential value of a

species, greater is its tendency to undergo reduction and stronger is the oxidising power.

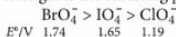

3. (a): Iodoform test is given by the compounds containing $\text{CH}_3\text{CO}-$ group or $\text{CH}_3\text{CH}(\text{OH})-$ group (which is oxidised to $\text{CH}_3\text{CO}-$ group). Sample is heated with I_2 and NaOH , the existence of yellow ppt. indicates the presence of $\text{CH}_3\text{CO}-$ group or $\text{CH}_3\text{CH}(\text{OH})-$ group.

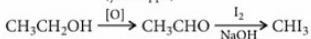
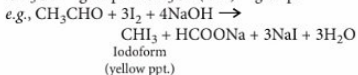

∴ *n*-Butyl alcohol ($\text{CH}_3\text{CH}_2\text{CH}_2\text{CH}_2\text{OH}$) does not give iodoform test as it does not possess the $\text{CH}_3\text{CO}-$ or $\text{CH}_3\text{CH}(\text{OH})-$ group.

4. (d): $E \propto \frac{1}{n^2}$ i.e., when $n = 3$; E decreases nine times.
5. (c): According to Hardy-Schulze rule, the flocculation power is directly proportional to the charge. Thus, correct order is:



6. (b): Stability of a complex depends upon the value of stability constant. Higher the value of K , more stable is the complex. Since, K is highest when $\log K$ is 27.3.
 Thus, $[\text{Cu}(\text{CN})_4]^{2-}$ is the most stable complex among the given complexes.
7. (a): Acidity decreases as the electronegativity of the central halogen decreases from Cl to I in HXO (oxoacids).

8. (d)
9. (b): Mass of oxygen in the oxide

$$= (1.020 - 0.540) = 0.480 \text{ g}$$

$$\text{Equivalent mass of the metal} = \frac{0.540}{0.480} \times 8 = 9.0$$

According to Dulong and Petit's law,

$$\text{Approx. atomic mass} = \frac{6.4}{\text{sp. heat}} = \frac{6.4}{0.216} = 29.63$$

$$\text{Valency of the metal} = \frac{\text{at. mass}}{\text{eq. mass}} = \frac{29.63}{9.0} \approx 3$$

Hence, the formula of the oxide is M_2O_3 .

10. (d): In this conformer Cl is at equatorial position and is least hindered.

11. (a): When $\Delta G_{\text{sys}} = 0$, the system is in equilibrium.

$$12. (d): E_{\text{cell}} = E_{\text{cell}}^{\circ} - \frac{RT}{nF} \ln \frac{[\text{Zn}^{2+}]}{[\text{Cu}^{2+}]}$$

$$\text{For I, } \frac{[\text{Zn}^{2+}]}{[\text{Cu}^{2+}]} = 1, \therefore E_{\text{cell}} = E_{\text{cell}}^{\circ}$$

$$\text{For II, } \frac{[\text{Zn}^{2+}]}{[\text{Cu}^{2+}]} = \frac{0.1}{1}$$

$$\therefore E_{\text{cell}} = E_{\text{cell}}^{\circ} - \frac{0.0591}{n} \log 10^{-1} = E_{\text{cell}}^{\circ} + \frac{0.0591}{n}$$

$$\text{For III, } \frac{[\text{Zn}^{2+}]}{[\text{Cu}^{2+}]} = \frac{1}{0.1} = 10$$

$$\therefore E_{\text{cell}} = E_{\text{cell}}^{\circ} - \frac{0.0591}{n} \log 10 = E_{\text{cell}}^{\circ} - \frac{0.0591}{n}$$

$$\therefore E_2 > E_1 > E_3$$

$$13. (b): \text{Number of moles of } \text{O}_2 = \frac{w}{M} = \frac{400 \times 10^{-3}}{32} = 0.0125$$

$$\text{Number of moles of } \text{H}_2 = \frac{w}{M} = \frac{60 \times 10^{-3}}{2} = 0.03$$

$$\text{From, } pV = nRT,$$

$$\text{Partial pressure of } \text{O}_2 = \frac{0.0125 \times 0.0821 \times 373}{1500 \times 10^{-3}} = 0.255 \text{ atm}$$

$$\text{Partial pressure of } \text{H}_2 = \frac{0.03 \times 0.0821 \times 373}{1500 \times 10^{-3}} = 0.612 \text{ atm}$$

$$\text{Total pressure} = 0.255 + 0.612 = 0.867 \text{ atm}$$

14. (a): Ionic radius of Fe^{3+} (0.64 Å) is less than that of Mn^{3+} (0.66 Å). Other properties vary as indicated.

15. (a): Compound X, Y and Z are Pb_3O_4 , PbO_2 and PbCl_2 .

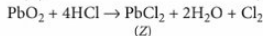
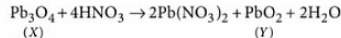

PbCl_2 is insoluble in cold water but soluble in hot water.

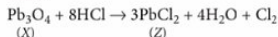

16. (c): Ionisation isomerism arises when the coordination compounds give different ions in solution, this condition is not satisfied with $[\text{Co}(\text{en})_2\text{Cl}_2]\text{Cl}$. It is an octahedral complex.

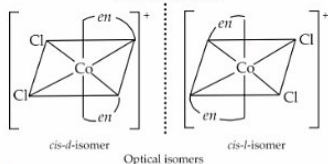
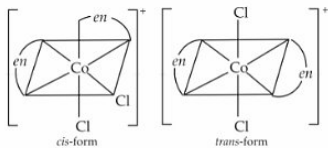

17. (c): CO_2 being symmetrical has zero dipole moment. Among HI , SO_2 and H_2O , dipole moment is highest for H_2O as the central atom in it contains 2 lone pairs.

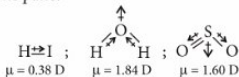

18. (d): For $\text{HIn} \rightleftharpoons \text{H}^+ + \text{In}^-$

$$K_a = \frac{[\text{H}^+][\text{In}^-]}{[\text{HIn}]}$$

$$\therefore \text{pH} = \text{p}K_a + \log \frac{[\text{In}^-]}{[\text{HIn}]}$$

$$\text{or } \text{pH} - \text{p}K_a = \log \frac{[\text{In}^-]}{[\text{HIn}]}$$

19. (a): The electronic configuration of Rb is $[\text{Kr}] 5s^1$. Thus, its valence electron enters in 5s-orbital.

For 5s orbital, $n = 5$

$l = 0$ (as orbital is s)

$$m = -l \text{ to } +l \text{ including zero, } m = 0; s = +\frac{1}{2}$$

Thus, the correct set of quantum numbers for the valence electron of rubidium is $5, 0, 0, +\frac{1}{2}$

20. (a): Let the solubility of AgCNS and AgBr in water be x and y respectively.

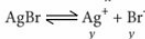
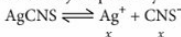

$$\therefore [\text{Ag}^+] = (x + y), [\text{CNS}^-] = x, [\text{Br}^-] = y$$

$$K_{sp}[\text{AgCNS}] = [\text{Ag}^+][\text{CNS}^-] = x(x + y)$$

$$\Rightarrow 1 \times 10^{-12} = x(x+y) \quad \dots(i)$$

$$\text{and } K_{sp}[\text{AgBr}] = [\text{Ag}^+][\text{Br}^-] = y(x+y)$$

$$\Rightarrow 5 \times 10^{-13} = y(x+y) \quad \dots(ii)$$

On solving Eq. (i) and (ii), we get

$$x = 8.16 \times 10^{-7} \text{ mol/L}$$

$$y = 4.08 \times 10^{-7} \text{ mol/L}$$

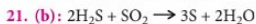

Here SO_2 acts as an oxidising agent and thus oxidises $\text{H}_2\text{S}(-2)$ to $\text{S}(0)$.

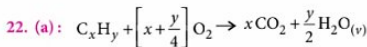

Initial vol.	500 mL	0	0
After reaction is complete	0	500x mL	$\frac{y}{2} \times 500$ mL

Now, $500x = 2500$

$$\therefore x = 5$$

$$\frac{500y}{2} = 3000$$

$$\therefore y = 12$$

Thus, the formula of alkane is C_5H_{12} .

23. (b): The complete structures of the given compounds are as follows :

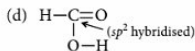
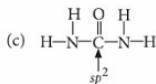
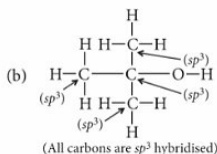
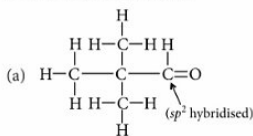

Thus, $(\text{CH}_3)_3\text{C}-\text{OH}$ uses only its sp^3 -hybrid orbitals for bond formation.

24. (d): Compound has $8 + 2 = 10\pi$ -electrons, hence it is aromatic.

has $4\pi e^-$ and has $8\pi e^-$ then, these are antiaromatic compounds while has $8 + 1 = 9\pi e^-$, hence, it is non-aromatic.

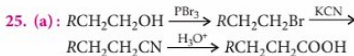

26. (b): London or photochemical smog are the mixture of smoke and fog. London smog is formed in cool humid climate when carbon soot particles combine with gaseous oxides of sulphur. Since in this type of smog, carbon and SO_2 are present, it is reducing in nature. Photochemical smog, on the other hand occurs in warm, dry and sunny climate. It results in the formation of PAN. Since in photochemical smog, O_3 is present, it irritates the eyes, nose, lungs, etc.

27. (b): Number of atoms present in the unit cell

$$Z = \frac{d \times a^3 \times N_A}{M}$$

Given, $M = 2.7 \times 10^{-2} \text{ kg mol}^{-1}$

$$a = 405 \text{ pm} = 405 \times 10^{-12} \text{ m} = 4.05 \times 10^{-10} \text{ m}$$

$$d = 2.7 \times 10^3 \text{ kg m}^{-3}$$

$$N_A = 6.022 \times 10^{23} \text{ mol}^{-1}$$

Hence,

$$Z = \frac{(2.7 \times 10^3 \text{ kg m}^{-3})(4.05 \times 10^{-10} \text{ m})^3 \times (6.022 \times 10^{23} \text{ mol}^{-1})}{(2.7 \times 10^{-2} \text{ kg mol}^{-1})} = 4$$

Since, there are four atoms per unit cell, the cubic unit cell must be face-centred.

28. (a): Dehydrohalogenation reaction is also called β -elimination reaction and the reactivity of haloalkanes towards elimination reaction is:

$$3^\circ > 2^\circ > 1^\circ.$$

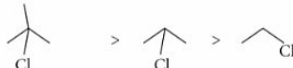

2-Chloro-2-methylpropane 3° III > 2-Chloropropane 2° II > 1-Chloroethane 1° I

29. (b): In general, electron releasing groups activate and electron withdrawing groups deactivate the benzene ring towards electrophilic substitution.

Hence, the correct order is :

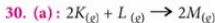
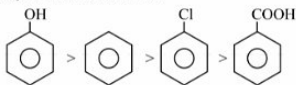

$$\Delta n_g = 2 - 3 = -1$$

$$\Delta H^\circ = \Delta U + \Delta n_g RT$$

$$= -10.5 \times 10^3 + (-1 \times 8.314 \times 298)$$

$$= -10500 + (-2477.572) = -12977.57 \text{ J} = -12.98 \text{ kJ}$$

$$\Delta G^\circ = \Delta H^\circ - T\Delta S^\circ$$

$$= -12.98 - 298 (-44.1 \times 10^{-3})$$

$$= -12.98 + 13.14 = 0.16 \text{ kJ}$$

Since ΔG° is +ve hence it is a non-spontaneous reaction.

31. (b):
$$\frac{P^\circ - P_s}{P^\circ} = \frac{\frac{w}{m}}{\frac{w}{m} + \frac{W}{M}}$$

w/m can be neglected in the denominator as compared to W/M .

$$\frac{w}{m} \times \frac{M}{W} = \frac{640 - 600}{640}$$

$$\frac{w}{m} \times \frac{M}{W} = \frac{40}{640} \Rightarrow \frac{2.175 \times 78}{m \times 39.08} = \frac{40}{640}$$

$$m = \frac{2.175 \times 78}{39.08} \times \frac{640}{40} = 69.46 \text{ g mol}^{-1}$$

32. (d): The structural formula of the complex X is $[\text{Cr}(\text{H}_2\text{O})_4\text{Br}_2]\text{Cl} \cdot \text{H}_2\text{O}$, one mole of which gives 2 moles of particles, i.e., $[\text{Cr}(\text{H}_2\text{O})_4\text{Br}_2]^+ + \text{Cl}^-$ and the formula of the complex Y is $[\text{Cr}(\text{H}_2\text{O})_5\text{Cl}]\text{Br}_2$, one mole of which gives 3 moles of particles, i.e., $[\text{Cr}(\text{H}_2\text{O})_5\text{Cl}]^{2+} + 2\text{Br}^-$.

33. (b): In $\text{CH}_3 - \text{C} \begin{matrix} \text{NH} \\ \diagup \\ \text{NH}_2 \end{matrix}$, lone pair on $-\text{NH}_2$ remains more available for donation and its conjugate acid is resonance stabilised thus, it is most basic. Between $\text{CH}_3\text{CH}_2\text{NH}_2$ and $(\text{CH}_3)_2\text{NH}$, the later is more basic because of the presence of two alkyl groups which facilitate the donation of lone pair of electrons.

$\text{CH}_3 - \text{C}(=\text{O}) - \text{NH}_2$ is least basic as the lone pair of N is involve in resonance.

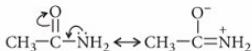

Thus, the correct order of basicity is I > III > II > IV.

34. (c): $(\text{AlH}_3)_n$ is a polymeric hydride like $(\text{BeH}_2)_n$, $(\text{MgH}_2)_m$ etc.

35. (a)

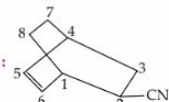

Bicyclo [2.2.2] oct-5-en-2-carbonitrile

37. (b): Cationic polymerisation is favoured by the presence of electron donating group (e.g., Me group). The more the electron donating group, the more stable is the intermediate carbocation, and as a result more favoured is the cationic polymerisation.

Stability of (C^+) is

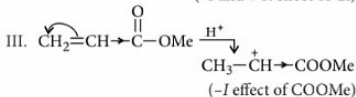
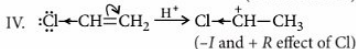
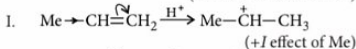
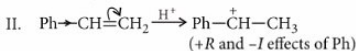

The decreasing reactivity order towards cation polymerisation is (II) > (I) > (IV) > (III).

38. (d): Proline has a 2° amino group. Hence, it is not estimated by this method.

39. (b): $-\text{COCH}_3$ group can be reduced to $-\text{CH}_2\text{CH}_3$ by either Zn-Hg, HCl or NH_2NH_2 , OH^- but with Zn-Hg, HCl, dehydration of alcohol takes place.

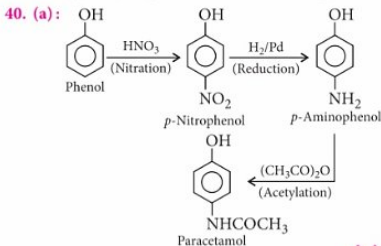

MONTHLY TEST DRIVE



This specially designed column enables students to self analyse their extent of understanding of specified chapters. Give yourself four marks for correct answer and deduct one mark for wrong answer. Self check table given at the end will help you to check your readiness.

Total Marks : 120

Time Taken : 60 Min.

NEET

Only One Option Correct Type

- At the same temperature calculate the ratio of average velocity of SO_2 to CH_4 .
(a) 2 : 3 (b) 3 : 4 (c) 1 : 2 (d) 1 : 6
- In which of the following the oxidation number of oxygen has been arranged in increasing order?
(a) $\text{OF}_2 < \text{KO}_2 < \text{BaO}_2 < \text{O}_3$
(b) $\text{BaO}_2 < \text{KO}_2 < \text{O}_3 < \text{OF}_2$
(c) $\text{BaO}_2 < \text{O}_3 < \text{OF}_2 < \text{KO}_2$
(d) $\text{OF}_2 < \text{O}_3 < \text{KO}_2 < \text{BaO}_2$
- For an indicator, HIn

$$\underset{A}{\text{HIn}} \rightleftharpoons \text{H}^+ + \underset{B}{\text{In}^-}$$

as the pH changes from $\text{p}K_{\text{In}} - 1$ to $\text{p}K_{\text{In}} + 1$, $\frac{[B]}{[A]}$
(a) will vary from 0.1 to 10
(b) will vary from 10 to 0.1
(c) will vary from 1 to 10
(d) will vary from 10 to 1.
- If 30 mL of H_2 and 20 mL of O_2 react to form water, what is left at the end of the reaction?
(a) 10 mL of H_2 (b) 5 mL of H_2
(c) 10 mL of O_2 (d) 5 mL of O_2
- The enthalpy of hydrogenation of cyclohexene is $-119.5 \text{ kJ mol}^{-1}$. If resonance energy of benzene is $-150.4 \text{ kJ mol}^{-1}$, its enthalpy of hydrogenation would be
(a) $-269.9 \text{ kJ mol}^{-1}$ (b) $-358.5 \text{ kJ mol}^{-1}$
(c) $-508.9 \text{ kJ mol}^{-1}$ (d) $-208.1 \text{ kJ mol}^{-1}$
- Borate salts when heated with conc. H_2SO_4 and $\text{C}_2\text{H}_5\text{OH}$ produce characteristic green colouration on flame due to the formation of a volatile compound
(a) $(\text{C}_2\text{H}_5)_3\text{B}$ (b) B_2H_6
(c) $(\text{C}_2\text{H}_5)_3\text{BO}_3$ (d) B_2O_3
- In diborane (B_2H_6) there are
(a) three $3c-2e^-$ bonds and three $2c-2e^-$ bonds
(b) four $3c-2e^-$ bonds and two $2c-2e^-$ bonds
(c) two $3c-2e^-$ bonds and four $2c-2e^-$ bonds
(d) none of the above.
- Cl_2 and SO_2 are pollutants but used in bleaching of textiles. Bleaching action of Cl_2 and SO_2 is due to

Cl_2	SO_2
(a) oxidation	oxidation
(b) reduction	reduction
(c) reduction	oxidation
(d) oxidation	reduction
- The correct IUPAC name of

$$\text{HOOC} - \underset{\text{COOH}}{\text{CH}} - \text{COOH}$$
is
(a) 2-carboxypropane-1, 3-dioic acid
(b) 2-carboxymalonic acid
(c) 1, 1, 1-tricarboxymethane
(d) propane-1, 2, 3-tricarboxylic acid.
- $(\text{CH}_3)_2\text{CHCH}=\text{CH}_2$ changes to A, B and C by using
 $(\text{CH}_3)_2\text{CHCH}_2\text{CH}_2\text{OH}$, $(\text{CH}_3)_2\text{CHCHCH}_3$,

(A)	(B)
-----	-----

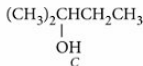

- (a) $\text{H}_2\text{O}/\text{H}^+$, $\text{BH}_3 \cdot \text{THF}/\text{H}_2\text{O}_2 \cdot \text{NaOH}$,
 $\text{Hg}(\text{OAc})_2/\text{NaBH}_4 \cdot \text{NaOH}$
 (b) $\text{H}_2\text{O}/\text{H}^+$, $\text{Hg}(\text{OAc})_2/\text{NaBH}_4 \cdot \text{NaOH}$,
 $\text{BH}_3 \cdot \text{THF}/\text{H}_2\text{O}_2 \cdot \text{NaOH}$
 (c) $\text{BH}_3 \cdot \text{THF}/\text{H}_2\text{O}_2 \cdot \text{NaOH}$,
 $\text{Hg}(\text{OAc})_2/\text{NaBH}_4 \cdot \text{NaOH}$, $\text{H}_2\text{O}/\text{H}^+$
 (d) $\text{BH}_3 \cdot \text{THF}/\text{H}_2\text{O}_2 \cdot \text{NaOH}$, $\text{H}_2\text{O}/\text{H}^+$,
 $\text{Hg}(\text{OAc})_2/\text{NaBH}_4 \cdot \text{NaOH}$

11. The number of electrons involved in the reduction of nitrate ion to hydrazine is
 (a) 8 (b) 7
 (c) 5 (d) 3
12. A certain mass of gas occupies a volume of 300 cc at 27°C and 620 mm pressure. The volume of this gas at 47°C and 640 mm pressure will be
 (a) 400 cc (b) 510 cc
 (c) 312 cc (d) 350 cc

Assertion & Reason Type

Directions : In the following questions, a statement of assertion is followed by a statement of reason. Mark the correct choice as :

- (a) If both assertion and reason are true and reason is the correct explanation of assertion.
 (b) If both assertion and reason are true but reason is not the correct explanation of assertion.
 (c) If assertion is true but reason is false.
 (d) If both assertion and reason are false.

13. **Assertion :** It is impossible to determine the exact position and exact momentum of an electron simultaneously.

Reason : The path of an electron in an atom is clearly defined.

14. **Assertion :** Kjeldahl method is not applicable to nitro compound, azo compound and pyridine.

Reason : Kjeldahl method is used for halogen estimation.

15. **Assertion :** Bromobenzene upon reaction with Br_2/Fe gives 1, 4-dibromobenzene as the major product.

Reason : In bromobenzene, the inductive effect of the bromo group is more dominant than the mesomeric effect in directing the incoming electrophile.

JEE MAIN / JEE ADVANCED

Only One Option Correct Type

16. An inorganic compound (X) which produces brick red colouration as flame. When (X) dissolves in water produces alkaline solution and a combustible gas (Y). (X) and (Y) are respectively.
 (a) CaO , O_2 (b) Ca_3N_2 , NH_3
 (c) CaCO_3 , CO_2 (d) CaH_2 , H_2
17. The correct order of acidic strength is
 (a) $\text{Cl}_2\text{O}_7 > \text{SO}_2 > \text{P}_4\text{O}_{10}$
 (b) $\text{K}_2\text{O} > \text{CaO} > \text{MgO}$
 (c) $\text{CO}_2 > \text{N}_2\text{O}_5 > \text{SO}_3$
 (d) $\text{Na}_2\text{O} > \text{MgO} > \text{Al}_2\text{O}_3$
18. The degree of dissociation of dinitrogen tetroxide, $\text{N}_2\text{O}_4(\text{g}) \rightarrow 2\text{NO}_2(\text{g})$ at temperature T and total pressure P is α . Which one of the following is the correct expression for the equilibrium constant (K_p) at this temperature?
 (a) $\frac{2\alpha}{(1-\alpha)^2}$ (b) $\frac{\alpha^2 P}{(1-\alpha)}$
 (c) $\frac{4\alpha^2}{(1-\alpha^2)}$ (d) $\frac{4\alpha^2 P}{(1-\alpha^2)}$

19. The configuration of 2, 3-dichloropentane whose structure is shown, is

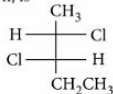

- (a) 2R, 3R (b) 2R, 3S
 (c) 2S, 3R (d) 2S, 3S

More than One Options Correct Type

20. Which of the following are wrong statements?
 (a) NO is more harmful than NO_2 .
 (b) SO_2 is more harmful than SO_3 .
 (c) Acid rain contains mainly HNO_3 .
 (d) Acid rain contains mainly H_2SO_4 and lesser concentrations of HNO_3 and HCl.
21. 22.44 kJ energy is required to convert 8 g of gaseous atom of metal M to $M_{(\text{g})}^+$ if $I.E._1$ of metal $M = 374$ kJ/mol. Select correct statement for metal M .
 (a) 0.6 mole gaseous ion (M^+) are formed.
 (b) Same energy can convert all $M_{(\text{g})}^+$ to $M_{(\text{g})}^{2+}$.
 (c) Atomic mass of metal = $133.33 \text{ g mol}^{-1}$.
 (d) 3.613×10^{22} atoms of M are converted to $M_{(\text{g})}^+$.

22. H_2 can be obtained from
 (a) the reaction of water with ionic hydrides
 (b) water gas by oxidation of CO into CO_2 (by steam) which can be easily removed by dissolving in H_2O
 (c) electrolysis of water
 (d) reaction of NaOH with Zn.
23. Isotones of $^{76}_{32}Ge$ are
 (a) $^{77}_{32}Ge$ (b) $^{77}_{33}As$ (c) $^{77}_{34}Se$ (d) $^{78}_{34}Se$

Numerical Value Type

24. $CH_3 - C \equiv CH \xrightarrow[2. D_3O^+]{1. NaNH_2} A \xrightarrow[Pd-BaSO_4]{D_2} B$
 Total number of deuterium atoms in the final product is
25. How many of the following metals liberate dihydrogen from water either at room temperature or on heating?
 Zn, Mg, Na, Al, Ti, Cr, W
26. The equilibrium constant K_{sp} for the given reaction is found to be $x \times 10^{-10}$.
 $AgCl_{(s)} \rightleftharpoons Ag^+_{(aq)} + Cl^-_{(aq)}$
 Using the data $\Delta G^{\circ}_f(AgCl) = -109.4$ kJ,
 $\Delta G^{\circ}_f(Ag^+) = 77.1$ kJ and $\Delta G^{\circ}_f(Cl^-) = -131.2$ kJ.
 The value of x is

Matrix Match Type

BeO and $Be(OH)_2$ are amphoteric while the oxides and hydroxides of other alkaline earth metals are basic. The solubility of hydroxides increases as we move down the group from Be to Ba but the solubility of sulphates and carbonates decreases in that order. The thermal stability of carbonates and sulphates of alkaline earth metals increases from Be to Ba as we move from top to bottom in the group.

27. Which of the following metal carbonates decomposes on heating?
 (a) $MgCO_3$ (b) Na_2CO_3
 (c) K_2CO_3 (d) Rb_2CO_3

28. The solubility in water of sulphates down the Be group is $Be > Mg > Ca > Sr > Ba$. This is due to
 (a) high heat of solvation for smaller ions like Be^{2+}
 (b) increasing molecular weight
 (c) decreasing lattice energy
 (d) increase in melting points.

29. Match the molecules given in Column I with their characteristics given in Column II.

Column I Column II

- | | |
|-------------|-------------------------------------|
| (A) O_2^- | (P) Bond order 2.5 and paramagnetic |
| (B) N_2 | (Q) Bond order 1.5 and paramagnetic |
| (C) N_2^+ | (R) Bond order 1 and paramagnetic |
| (D) B_2 | (S) Bond order 3 and diamagnetic |

A B C D

- | | | | |
|-------|---|---|---|
| (a) Q | S | P | R |
| (b) P | S | R | Q |
| (c) R | P | Q | S |
| (d) Q | S | R | P |

30. Match the terms given in Column I with the compounds given in Column II.

Column I Column II

- (A) Markovnikov (P) $CH_3 - CH = CH_2 \xrightarrow[H_2O_2, hv]{HBr}$ product

- (B) Anti-Markovnikov (Q) $\begin{matrix} H_3C & & CH_3 \\ & \diagdown & / \\ & C = C \\ & / & \diagdown \\ H & & H \end{matrix} \xrightarrow{CHCl_3 + KOH}$ product

- (C) Peroxide effect (R) $\text{C}_6\text{H}_5 - CH = CH_2 \xrightarrow{HCl}$

- (D) Mixture of stereoisomers (S) $CF_3 - CH = CH_2 \xrightarrow{HBr}$

- | | | | |
|----------|------|------|------|
| A | B | C | D |
| (a) R | P, S | P | Q, R |
| (b) P | P, S | Q, R | R |
| (c) R | P, S | Q | R |
| (d) Q, R | P, S | R | Q |

Keys are published in this issue. Search now! 

SELF CHECK

No. of questions attempted
 No. of questions correct
 Marks scored in percentage

Check your score! If your score is

- | | | |
|-----------------|--------------------------|------------------------------------------------------------|
| > 90% | EXCELLENT WORK! | You are well prepared to take the challenge of final exam. |
| 90-75% | GOOD WORK! | You can score good in the final exam. |
| 74-60% | SATISFACTORY! | You need to score more next time. |
| < 60% | NOT SATISFACTORY! | Revise thoroughly and strengthen your concepts. |

LEARNFAST

Electron Displacements in Organic Compounds

The behaviour of an organic compound is influenced to a large extent by the electron displacements taking place in its covalent bonds. These displacements may be of permanent nature or temporary which take place in presence of another species in the molecule. The acidity and basicity of organic compounds, their stability, their reactivity towards other substances, etc. can easily be predicted by considering such electronic displacements.

Inductive Effect

- This is a permanent effect operating in polar covalent bonds. The induction of a permanent dipole in a covalent bond bearing two unlike atoms of different electronegativities is referred to as the inductive effect.
- The development of partial +ve and -ve charges is due to the drift of the shared pair of electrons towards the more electronegative atom resulting in the origin of small fractional charges on the constituent atoms.
- When a carbon atom is bonded to a hydrogen (C - H) or another carbon (C - C) atom by a covalent bond such as in alkanes, the sharing of electron pair is symmetrical between them.

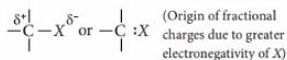
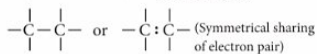
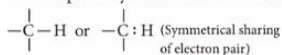

- The direction of displacement is shown by placing an arrow head midway along the line representing the sigma bond.

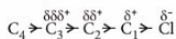

- The inductive effect of an atom or a group of atoms diminishes rapidly with distance. In fact, the

inductive effect is almost negligible beyond two carbon atoms from the active atom or group.

- Inductive effect does not involve actual transfer of electrons from one atom to another but merely helps in displacing them permanently.

Groups with -I effect :

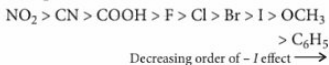

Groups with +I effect :



- The phenomenon of inductive effect is very important in organic chemistry as it is helpful in explaining a number of facts.

- **Reactivity of alkyl halides** : The presence of halogen atoms in the molecule of alkyl halide creates a centre of low electron density which is readily attacked by the negatively charged reagents.

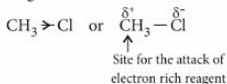

- **Dipole moment** : As the inductive effect increases, the dipole moment increases.



- **Relative acid strength of chloroacetic acids and acetic acid :**

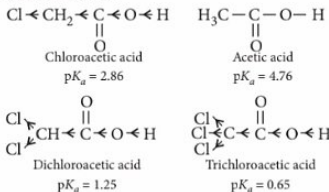

The decreasing order of acid strength :



- Relative acid strength of formic acid and acetic acid :



Methyl group has an electron releasing inductive effect (+I effect). Therefore acetic acid is a weaker acid than formic acid.

- Relative acid strength of fluoroacetic acid, chloroacetic acid, bromoacetic acid and iodoacetic acid : Halogenated acids are much stronger acids than the parent acid and the acidity increases almost proportionately with the increase in electronegativity of the halogen present which helps in repelling the proton from the hydroxy group of acid.

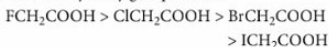

Since the inductive effect decreases with increase in distance of halogen atom from the carboxylic group, the strength of the acid is proportionately decreased.

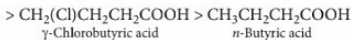
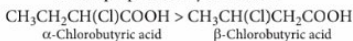

- Relative reactivity of toluene (methylbenzene) and benzene in aromatic substitution reactions : Aromatic substitution reactions are generally electrophilic in nature. Methyl has an electron releasing inductive effect (+I effect). Therefore, toluene with higher electron density is more reactive than benzene in electrophilic substitution reactions.

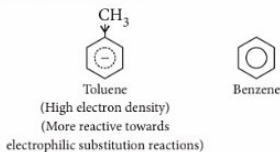

- Relative reactivity of nitrobenzene and benzene in electrophilic aromatic substitution reactions :

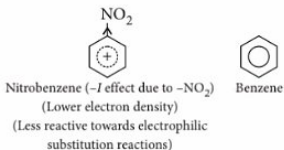

- Relative acid strength of water, phenol and methyl alcohol : As compared to water, phenol is more acidic (-I effect) but methyl alcohol is less acidic (+I effect).

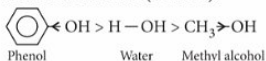

- Strength of base : A compound is said to be basic in nature, if it is capable of accepting a proton. Base strength is defined as the tendency to donate an electron pair for sharing. The difference in base strength can be explained on the basis of inductive effect.

As compared to ammonia, methylamine is more basic (+I effect) while aniline is less basic and diphenylamine is a still weaker base (-I effect).



The decreasing order of base strength in alcohols is due to +I effect of alkyl groups.

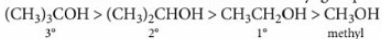

Greater the tendency to donate electron pair for coordination with proton, more is the basic nature, i.e., more the negative charge on nitrogen atom (due to +I effect of alkyl group), higher is the basic strength.

Thus, the basic nature decreases in the order,

Alkyl group Relative basic strength

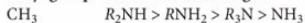

- Relative stabilities of carbocations :



- Reactivity of carbonyl compounds in nucleophilic addition reactions : +I group increases electron availability on carbonyl carbon. This therefore decreases the rate of nucleophilic addition. On the other hand, electron withdrawing -I effect decreases electron availability on carbonyl carbon and thereby increases the rate of nucleophilic addition.

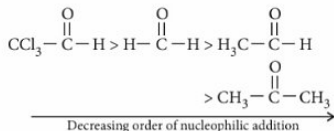

- Inductive effect is also dependent on the difference in the state of hybridisation of the atoms linked by covalent bond.

Relative acidity of hydrocarbons may be given as:

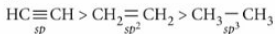

Relative basicity of corresponding carbanions is as:

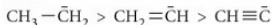

- The acid strength of acrylic acid ($\text{CH}_2=\text{CHCOOH}$) is considerably higher than that of propionic acid ($\text{CH}_3\text{CH}_2\text{COOH}$) due to the electron withdrawing inductive effect of the sp^2 -hybridised carbon atom of the α,β -double bond even though the resonance effect of the α,β -unsaturated carbon system would tend to decrease the acid strength.

Field Effect

- Inductive effect is a permanent effect in the ground state of the molecule and usually operates through single bonds. However, when the inductive effect is transmitted through space or solvent molecules, it is known as field effect.

- The two chlorine atoms in (I) and (II) exert the same inductive effect with respect to the position of electrons associated with the $-\text{COOH}$ group and consequently the two compounds should exhibit the same acid strength.

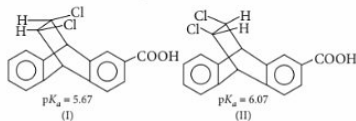

However, the two chlorine atoms in the molecule (I), being closer to the acid group as compared to (II), will exert greater electron withdrawing effect in (I) as compared to (II). Hence the isomer (I) is a stronger acid than (II).

Electromeric Effect

- This is a temporary effect operating in unsaturated compounds only at the demand of a nearby reagent and as soon as this attacking reagent is removed, the original condition is restored.

- It involves the complete transfer of π -electrons of multiple bond, because π -bonds are loosely held and easily polarisable.

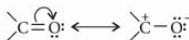

Thus the complete transfer of shared pair of π -electrons of a multiple bond to the more electronegative atom of the bonded atoms due to the requirement of an attacking reagent is called electromeric effect (E -effect).

- When the transfer of π -electrons takes place towards the attacking reagent (electrophile), the effect is called $+E$ -effect.

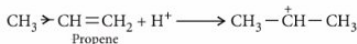
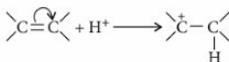

- When the transfer of electrons takes place away from the attacking reagent, the effect is called $-E$ -effect.

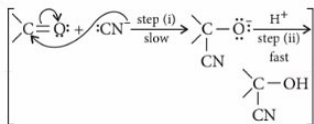
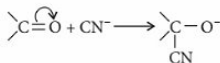

- When the I - and E -effect occur together in a molecule, they may be assisting or opposing each other. When they are opposing, the E -effect generally dominates over I -effect.

Applications:

- Electrophilic addition reactions of unsaturated compounds involve the polarisation of the carbon-carbon double bond in the presence of attacking electrophiles like H^+ .

- Nucleophilic addition reactions of carbonyl compounds involve polarisation through electromeric effect of the carbon-oxygen double bond in the presence of a nucleophile.
- Electrophilic substitution reactions of benzenoids involve polarisation through electromeric effect of the benzene ring when an electrophile (E^+) approaches them.

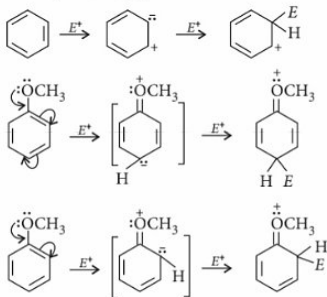

Hyperconjugation

- Hyperconjugation is the stabilizing interaction that results from the interaction of the electrons in a sigma bond (usually C-H or C-C) with an adjacent empty or partially filled non-bonding π -orbital or antibonding p -orbital to give an extended molecular orbital that increases the stability of the system.
- Conjugated dienes like 1,3-butadiene have been found to be more stable than simple alkenes like 1-butene. This has been explained in terms of delocalization of π -electrons.
- Besides conjugation even alkyl groups bearing hydrogen on the carbon that is attached to doubly bonded carbon atoms tend to increase the stability of alkenes.
- Propene ($\text{CH}_3-\text{CH}=\text{CH}_2$) for example has been found to be more stable than ethene ($\text{CH}_2=\text{CH}_2$) by about 11 kJ/mole.

This can be explained in terms of delocalization of electrons which takes place by the overlapping between a π -orbital of carbon and a σ -orbital of the H of methyl group. As a result of this overlapping, each pair of electrons does not just bind together two atoms *i.e.*, the doubly bonded carbons or the carbon and

hydrogen but all the four atoms. This delocalization which involves σ -bond orbitals also, is referred to as hyperconjugation or σ, π -conjugation.

- The concept of hyperconjugation was developed on the basis of discovery of anomalous electron releasing pattern of alkyl groups. The inductive (+I) effect of alkyl groups is normally in the following order :

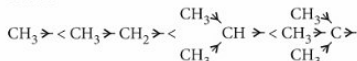

- Baker and Nathan observed that when alkyl groups are attached to an unsaturated system, the order of inductive effect is disturbed and in some cases actually reversed. For example, the rate of reaction of *p*-alkyl benzyl bromide with pyridine was contrary to what was expected from the order of the inductive effect of the substituent alkyl group *i.e.*, rate of the above reaction follows the order : methyl > ethyl > isopropyl > *tert* butyl.

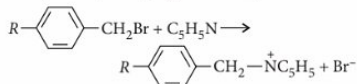

This effect is known as Baker-Nathan effect. It is a permanent effect. In fact hyperconjugation is an extension of resonance.

- Resonance effect involves delocalization of π -electrons of two or more conjugated double bonds while hyperconjugation involves delocalization of σ -electrons. Hyperconjugation can be described as double bond - no bond resonance.
- Conjugation between the σ -electrons of single bond and π -electrons of multiple bond *i.e.*, σ, π -conjugation is known as hyperconjugation.
- **Hyperconjugation is of two types :**

- **Sacrificial hyperconjugation :** The essential condition is the attachment of alkyl group to double bond or triple bond.

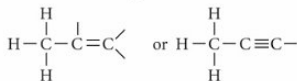

Carbon atom of alkyl group attached to double bond must contain at least one hydrogen atom in hyperconjugation.

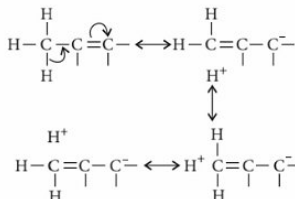

It involves a sort of sacrifice of bond.

- **Isovalent hyperconjugation** : This kind of hyperconjugation involves no sacrifice of bonds. Ethyl radicals have the same number of real bonds as the classical structure.

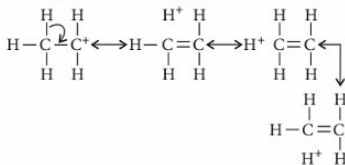

- **Significance of hyperconjugation** :

- **Heat of hydrogenation** :

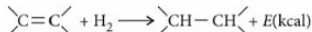

Lesser the heat of hydrogenation, lesser is the internal energy and more is the stability of the system. Hyperconjugation decreases the heat of hydrogenation.

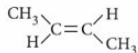

trans-2-Butene
 $\Delta H = 27.6 \text{ kcal/mol}$

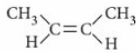
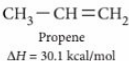

cis-2-Butene
 $\Delta H = 28.6 \text{ kcal/mol}$

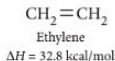

cis-2-Butene is less stable than *trans*-2-butene due to repulsion between two bulkier groups close to each other.

- **Stability of carbonium ions** : Greater the number of H-atoms present on the carbon atoms α to unsaturation, more are the resonating forms possible due to hyperconjugation and thus greater is the stability of carbonium ion.

- **Bond length** : Hyperconjugation, like conjugation and resonance, also affects bond length.

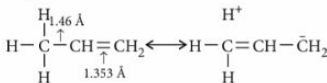

Bond length in propene is 1.46 \AA in contrast to normal 1.54 \AA (in propane). It is due to the partial double bond character acquired and hence a little shorter.

- **Dipole moment** : Since hyperconjugation causes the development of charges, it also affects the dipole moment in the molecule.

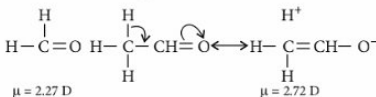

- *Ortho-para* directing property of methyl group in toluene is partly due to +I effect and partly due to hyperconjugation.

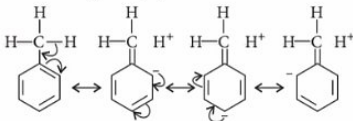

Resonance Effect

- The concept of resonance pertains to the fact that there are a number of compounds which could be assigned two or more Lewis structures, differing only in the relative position of electrons. However, the actual properties of the substance are not represented by any of these structures but by a structure which is a 'blend' or 'hybrid' of various contributing structures. For example, the following three Lewis structures can be written for the carbonate anion.

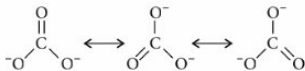

These structures reveal that the carbonate anion contains two carbon-oxygen single bonds and one carbon-oxygen double bond but neither of these predictions is consistent with the observation that

mtg

For Inquiries
1800 10 38673

Find all your
QUESTIONS here,
before getting them
in your exam.

By not studying
MORE but
ACCURATE...



Our
Books



₹800/-



₹800/-



₹800/-

JEE 2020 exams are nearing and all the students must be in the stage of preparation with full dedication and hard work. But have you put your knowledge to test? With our 38 years of experience, we would suggest you to put yourself through MTG's JEE Champion Series so that you can be sure about your level of preparation and find your core strengths and capabilities. The best part is you study at a pace you're comfortable with. Because it's all chapters, topicwise.



Attempt all questions from this book on the **Web + Mobile for free**
See Instructions inside

all the C – O bonds in carbonate anion are of equal length (1.30 Å).

- If single and double bonds are present alternatively in a molecule (in case of conjugated system) then π -electrons are delocalized *i.e.*, electrons can flow from one part to another part of the system. This flow of electrons is due to resonance and it results in polarity of the system.



This effect is called mesomeric effect and is transmitted throughout the chain. This is also a permanent effect like inductive effect.

- **Resonance effect is of two types :**

- **+M or +R effect :** The groups which donate the electrons to the double bond or to a conjugated system are said to have +M effect or +R effect. *e.g.*, –OH, –OR, –NHR, –NR₂, –Cl, –Br, –I, etc.

- **–M or –R effect :** The groups which withdraw the electrons from the double bond or from a conjugated system towards themselves are said to have –M effect or –R effect. *e.g.*, $\text{>C}=\text{O}$, –CHO, –CN, –NO₂, –COOR, etc.

- The term mesomerism is used synonymously with resonance. Molecule showing resonance involves overlap of *p*-orbitals in both directions and there is participation of each *p*-electron in more than one bond. In other words resonance and delocalization are used often in the same sense.

- **Resonance energy :** Resonance hybrid is more stable than any single discrete structure. This can be explained in terms of energy of stabilization known as resonance energy. The resonance energy is calculated from the difference between the theoretical and experimental heats of hydrogenation of the compound.

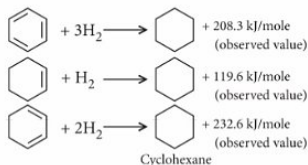

The main postulates of resonance theory are :

- Resonating structures should differ only in the position of electrons, not in the position of atoms.
- Resonating structures should have the same number of unpaired electrons.
- Greater the stability of a contributing structure, greater is its contribution to the hybrid.
- Smaller the difference in the energy contents (or stabilities) of the contributing structures, greater is the resonance energy of that hybrid.
- The polar contributing structures involving distinct charges, are less stable (and hence less important) than those which do not involve any charges.
- Greater the number of contributing structures, greater is the stability.
- Larger the number of bonds in a contributing structure, greater is the stability of that structure.
- All the atoms should have octet of electrons except hydrogen which has duplet. The resonance structures which violate octet rule, should not be considered.
- The skeleton of the molecule should be planar in conjugated system which is necessary in order to achieve maximum overlap of *p*-orbitals. Any structural feature that destroys coplanarity of the conjugated system inhibits resonance. This inhibition is known as steric inhibition of resonance.
- In resonance hybrid, the bond lengths are different from those in the contributing structures.
- No. of π -bonds \propto No. of contributing structures
 \propto Resonance energy \propto Stability

- **Applications :**

- By knowing the resonating structures, we can get bond order in a given ion as :

$$\text{Bond order} = \frac{\text{Total no. of bonds}}{\text{Total no. of resonating structures}}$$

- Resonating structures of dienes :

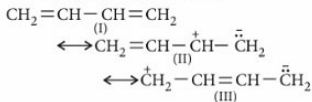

The contributing structures (II) and (III) provide a satisfactory explanation for 1,2 and 1,4 addition and stability of conjugated dienes over simple alkenes.

- All the carbon-carbon bonds in benzene are equivalent, (there are no true single and double bonds as expected from the contributing structures) having exactly the same length (139 pm).

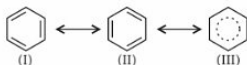

Besides this, benzene has large resonance energy (151 kJ/mole) and hence stability is expected for this system.

- The lower pK_a values of nitromethane and acetyl acetone are simply because of resonance stabilisation of their conjugate bases.

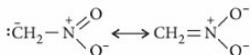

Resonance stabilised conjugate base of nitromethane

- The acidity of carboxyl group is primarily because of ease of proton release and later, the conjugate base carboxylate ion, is stabilised by forming two equivalent contributing forms.

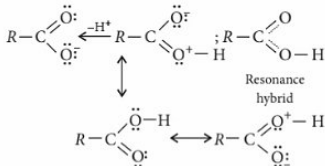

- Acidity of α -hydrogen in carbonyl compounds** : This is due to the resonance stabilisation of resulting carbanions.

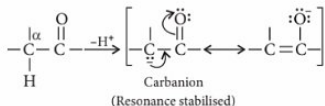

- Stability of triphenylmethyl cation** : Its stability is due to the extensive delocalisation of the positive charge.

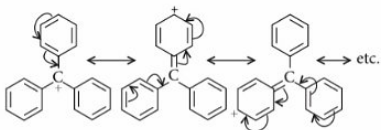

- Acidic character of phenols** : Phenol is a weak acid. The acidic nature of phenol is due to the formation of stable phenoxide ion in solution.

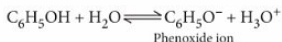

Phenoxide ion is stable due to resonance.

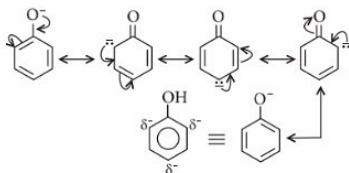

The negative charge is spread throughout the benzene ring. This charge delocalization is a stabilizing factor in the phenoxide ion and increased acidity of phenol. No resonance is possible in alkoxide ions (RO^-) derived from alcohols. The negative charge is localized on oxygen atom. Thus, alcohols are less acidic than phenols.

- Effect of substituents on the acidity of phenols** : Presence of electron attracting group ($-\text{NO}_2$, $-\text{NR}_3^+$, $-\text{CN}$, $-\text{CHO}$, $-\text{COOH}$) on the benzene ring increases the acidity of phenol. Nitro group in nitro phenol if present in ortho and para positions would stabilise the phenoxide ion by dispersal of negative charge through resonance or mesomeric effect, to a greater extent and will be more acidic than phenol.
- Base weakening effect of amines** : In case of aryl amines, resonance effect comes into play. Aniline, for example is a resonance hybrid of structures I to V.

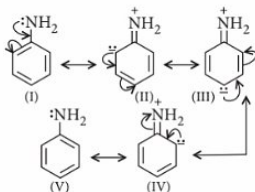

Aniline is far less basic than aliphatic amines, primarily due to its resonance stabilization and secondarily, the anilinium cation loses the stabilization because of protonation. Electron withdrawing groups like $-\text{NO}_2$ when present at *o*- or *p*- position with respect to aniline will further weaken the basic character of aniline. e.g., *p*-nitroaniline is a weaker base than aniline. The extra base weakening effect when nitro is in the *o*-position, is primarily due to short distance ($-I$ effect assisting the resonance), and secondarily, because of direct interaction (both steric and hydrogen bonding). Thus, *o*-nitroaniline is such a weak base that its salts are largely hydrolysed in aqueous solution.

In contrast to amines, the amides and imides are much less basic because of the resonance stabilisation of the molecules. It is practically difficult to protonate an imide.

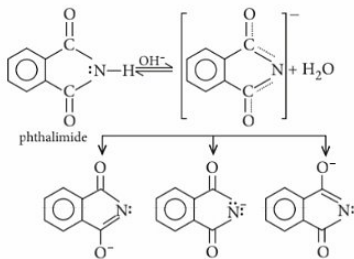
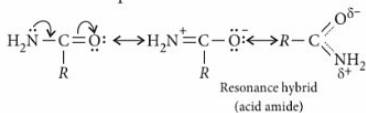

Resonance Effect vs Inductive Effect

Both are permanent effects, but there are significant differences between the two which are outlined below :

- Resonance effect operates in unsaturated (preferably one with a conjugated system) compounds while inductive effect operates in compounds containing σ -bonds. In other words, π -electrons are involved in resonance effect but only σ -electrons are involved in inductive effect.
- Inductive effect is distance dependent (its intensity decreases sharply with distance from the crucial atom in the chain) while resonance effect is not.
- Resonance effect involves delocalisation of electrons, but there is no such delocalisation in compounds showing inductive effect.

Directive or Orientation Effect

The substituent already present on the benzene ring directs the incoming substituent to occupy, (2 or 6) *ortho*, *meta* (3 or 5) or *para* (4) position. This direction depends on the nature of the first substituent and is called directive or the orientation effect.

- **Class I : (*o*, *p*-directing groups) :** $-\text{R}$ (alkyl), $-\text{OH}$, $-\text{SH}$, $-\text{NH}_2$, $-\text{OR}$, $-\text{NHR}$, $-\text{NR}_2$, $-\text{NHCOR}$, $-\text{Cl}$, $-\text{Br}$, $-\text{I}$, $-\text{CH}_2\text{Cl}$, $-\text{CH}_2\text{OH}$, $-\text{CH}_2\text{NH}_2$, $-\text{CH}_2\text{CN}$, $-\text{CH}_2\text{COOH}$, $-\text{CH}=\text{CH}_2$, $-\text{CH}=\text{CHCOOH}$, $-\text{C}_6\text{H}_5$, $-\text{N}=\text{N}$, $-\text{NC}$, etc.
- **Class II : (*m*-directing groups) :** $-\text{SO}_3\text{H}$, $-\text{NO}_2$, $-\text{CHO}$, $-\text{COOH}$, $-\text{CN}$, $-\text{NH}_3\text{Cl}$, $-\text{SO}_2\text{Cl}$, $-\text{COCl}$, $-\text{COOR}$, $-\text{COR}$, $-\text{CCl}_3$, $-\text{NH}_3^+$, $-\text{NH}_2\text{R}^+$, $-\text{NR}_3^+$, etc.

All *ortho*, *para*-directing substituents possess atleast one non-bonding electron pair on the 'key atom'

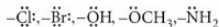

The only exception to the above rule is the methyl or alkyl group.

- **Theory of directive effects :** The resonance theory clearly explains why certain substituents are *ortho-para* directing, while others are *meta* directing.

- ortho-para Directing :** The non-bonding electron pair of the key atom of the substituent is delocalized on the ring by interaction with the π -system due to which *ortho* and *para* positions attain greater electron density and the electrophile (E^+) would naturally attack at these electron rich centres forming *ortho* and *para* isomers. *ortho-para* Directing groups activate the benzene ring towards electrophilic substitution while *meta* directing groups deactivate the benzene nucleus towards electrophilic substitution.

$-\text{F}$, $-\text{Cl}$, $-\text{Br}$ and $-\text{I}$ (halogens) are exceptions to the above rule. These groups are *o*-, *p*- directing but deactivate the ring.

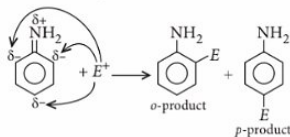

- meta-Directing :** The substituent withdraws electrons from *ortho* and *para*-positions. Thus, *m*-position becomes a point of relatively high electron density and further substitution by electrophile occurs at *meta*-position.

Any substituent or group which releases (donates) electrons into the ring (*i.e.*, *o*-, *p*-directing) activates the benzene ring for further substitution. The substituent which withdraws electrons (*m*-directing) from the ring deactivates the benzene ring for further substitution.

In case of halogen $-I$ effect predominates resonance effect.

$-\text{NO}_2$ group is *meta*-directing (electron withdrawing), its mechanism can be explained as

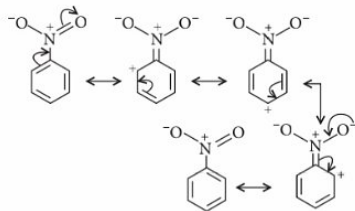

All *meta*-directing groups have either a partial positive charge or a full positive charge on the atom directly attached to the ring.

Introduction of a Third Substituent into Benzene Ring

The position occupied by a third substituent group entering the benzene ring is mainly decided by the nature of the two groups already present on the benzene ring.

- When both groups are (*o*-, *p*-directing) then the directive influence of each group is in the following order :

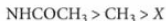

The new group enters *p*-position preferably with respect to more powerful group.

In case the *p*-position is blocked, the third group enters the position *ortho* to the more powerful group.

- When both groups are *meta*-directing the third group is accommodated according to the following order :



The new substituent occupies *meta*-position with respect to the more powerful group.

- When two groups exert different directive influence then *o*-, *p*-directors take precedence.

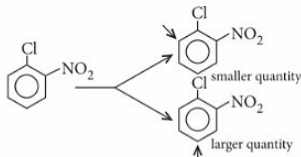

- In case the influence of two groups reinforce each other, the third group is attached to one position, only.

Monthly Test Drive CLASS XI ANSWER KEY

- | | | | | |
|-----------|---------------|-----------|---------|-------------|
| 1. (c) | 2. (b) | 3. (a) | 4. (d) | 5. (d) |
| 6. (c) | 7. (c) | 8. (d) | 9. (a) | 10. (c) |
| 11. (b) | 12. (c) | 13. (c) | 14. (c) | 15. (c) |
| 16. (d) | 17. (a) | 18. (d) | 19. (d) | 20. (a,b,c) |
| 21. (c,d) | 22. (a,b,c,d) | 23. (b,d) | 24. (3) | 25. (4) |
| 26. (2) | 27. (a) | 28. (a) | 29. (a) | 30. (a) |

MONTHLY TEST DRIVE



This specially designed column enables students to self analyse their extent of understanding of specified chapters. Give yourself four marks for correct answer and deduct one mark for wrong answer. Self check table given at the end will help you to check your readiness.

Total Marks : 120

Time Taken : 60 Min.

NEET

Only One Option Correct Type

1. The Born Haber cycle for rubidium chloride (RbCl) is given below (the energies are in kcal/mol⁻¹)

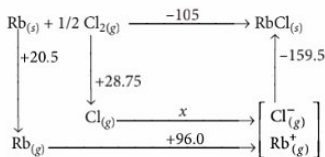

What is the electron affinity of chlorine?

- (a) -105 kcal/mol (b) -90.75 kcal/mol
 (c) 14.5 kcal/mol (d) 25.75 kcal/mol
2. Which of the following is correct?
 (a) Duralumin : Al + Cu + Mg + Ag
 (b) German silver : Cu + Zn + C
 (c) Gun metal : Cu + Zn + Sn
 (d) Solder : Pb + Al
3. The most suitable reagent 'A', for the reaction

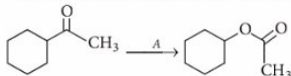

is

- (a) O₃
 (b) H₂O₂
 (c) NaOH-H₂O₂
 (d) *m*-Cl-(C₆H₄COOH)

4. An organic compound having molecular mass 60 is found to contain C = 20%, H = 6.67% and N = 46.67% while rest is oxygen. On heating, it gives NH₃ along with a solid residue. The solid residue gives violet colour with alkaline copper sulphate solution. The compound is
 (a) CH₃CONH₂ (b) CH₃NCO
 (c) CH₃CH₂CONH₂ (d) (NH₂)₂CO
5. The cubic unit cell of Al (molar mass = 27 g mol⁻¹) has an edge length of 405 pm and density 2.7 g cm⁻³. The cubic unit cell is
 (a) body centred (b) primitive
 (c) edge centred (d) face centred.
6. A reaction was observed for 15 days and the percentage of the reactant remaining after the days indicated was recorded in the following table :

Time (days)	% Reactant remaining
0	100
2	50
4	39
6	25
8	21
10	18
12	15
14	12.5
15	10

Which one of the following best describes the order and half-life of the reaction?

Reaction order Half-life (days)

- (a) First 2
 (b) First 6
 (c) Second 2
 (d) Zero 6

7. The number of possible enantiomeric pairs that can be produced during mono-chlorination of 2-methylbutane is

- (a) 3 (b) 4 (c) 1 (d) 2

8. The degree of dissociation (α) of a weak electrolyte, A_xB_y is related to van't Hoff factor (i) by the expression

- (a) $\alpha = \frac{x+y-1}{i-1}$ (b) $\alpha = \frac{x+y+1}{i-1}$
 (c) $\alpha = \frac{i-1}{(x+y-1)}$ (d) $\alpha = \frac{i-1}{x+y+1}$

9. The coagulation values in millimoles per litre of the electrolytes used for the coagulation of As_2S_3 are given below :



- I. NaCl = 52
 II. $BaCl_2$ = 0.69
 III. $MgSO_4$ = 0.22

The correct order of their coagulating power is

- (a) I > II > III (b) II > I > III
 (c) III > II > I (d) III > I > II

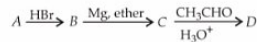
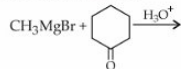
10. In the following sequence of the reactions, identify the final product D.

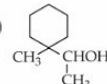

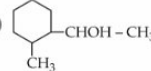
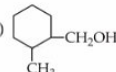
- (a)  (b) 
 (c)  (d) 

11. Pick out the incorrect statements from the following.

- Glucose exists in two different crystalline forms, α -D-glucose and β -D-glucose.
 - α -D-glucose and β -D-glucose are anomers.
 - α -D-glucose and β -D-glucose are enantiomers.
 - Cellulose is a straight chain polysaccharide made of only β -D-glucose units.
 - Starch is a mixture of amylose and amylopectin, both contain unbranched chain of α -D-glucose units.
- (a) 1 and 2 only (b) 2 and 3 only
 (c) 3 and 4 only (d) 3 and 5 only

12. When the imidazole ring of histidine is protonated, the tendency of nitrogen to be protonated (proton migrates from $-COOH$) is in the order

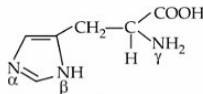

- (a) $\beta > \gamma > \alpha$ (b) $\gamma > \beta > \alpha$
 (c) $\gamma > \alpha > \beta$ (d) $\beta > \alpha > \gamma$

Assertion & Reason Type

Directions : In the following questions, a statement of assertion is followed by a statement of reason. Mark the correct choice as :

- (a) If both assertion and reason are true and reason is the correct explanation of assertion.
 (b) If both assertion and reason are true but reason is not the correct explanation of assertion.
 (c) If assertion is true but reason is false.
 (d) If both assertion and reason are false.

13. **Assertion :** A mixture of 2-nitrophenol and 4-nitrophenol can be separated by steam distillation.

Reason : 2-Nitrophenol is intramolecularly H-bonded while 4-nitrophenol is intermolecularly H-bonded.

14. **Assertion :** Chloroform is stored in dark coloured bottles.

Reason : Chronic chloroform exposure may cause damage to liver and kidneys.

15. **Assertion :** Hydrometallurgy involves dissolving the ore in a suitable reagent followed by precipitation by a more electropositive metal.

Reason : Copper in bulk quantity is extracted by hydrometallurgy.

16. 0.001 mol of cobalt complex having molecular formula represented by $\text{Co}(\text{NH}_3)_5(\text{NO}_3)(\text{SO}_4)$ was passed through a cation exchanger (RSO_3H) and the acid coming out of it, was titrated with 0.1 M NaOH solution. For complete neutralisation of acid coming out of cation exchanger, the volume of NaOH required was 20.00 mL. From the above data we can say that the complex can be represented as
- $[\text{Co}(\text{NH}_3)_5(\text{NO}_3)(\text{SO}_4)]$
 - $[\text{Co}(\text{NH}_3)_5\text{SO}_4]\text{NO}_3$
 - $[\text{Co}(\text{NH}_3)_5\text{NO}_3]\text{SO}_4$
 - none of the above.
17. What is the dominant intermolecular force or bond that must be overcome in converting liquid CH_3OH to a gas?
- Dipole-dipole interactions
 - Covalent bonds
 - London-dispersion forces
 - Hydrogen bonding
18. Calculate the amount of ice that will separate out on cooling a solution containing 50 g of ethylene glycol in 200 g of water to -9.3°C . (K_f for water = 1.86 K m^{-1})
- 161.29 g
 - 38.71 g
 - 54.12 g
 - 77.42 g
19. The incorrect statements among the following are
- NCl_5 does not exist while PCl_5 does.
 - Lead prefers to form tetravalent compounds.
 - The three C—O bonds are not equal in carbonate ion.
 - Both O_2^+ and NO are paramagnetic.
- I, III and IV only
 - I and IV only
 - II and III only
 - I and III only

More than One Options Correct Type

20. The carbon based reduction method is not used for extraction of
- Sn from SnO_2
 - Fe from Fe_2O_3
 - Al from Al_2O_3
 - Mg from $\text{MgCO}_3 \cdot \text{CaCO}_3$

21. For the cell, $\text{Ti}|\text{Ti}^+ (0.001 \text{ M})||\text{Cu}^{2+} (0.1 \text{ M})|\text{Cu}$, E_{cell} at 25°C is 0.826 V. The EMF can be increased
- by increasing $[\text{Ti}^+]$
 - by decreasing $[\text{Ti}^+]$
 - by increasing $[\text{Cu}^{2+}]$
 - by decreasing $[\text{Cu}^{2+}]$.
22. Which of the following reagents can be used to oxidise primary alcohols to aldehydes?
- CrO_3 in anhydrous medium
 - KMnO_4 in acidic medium
 - Pyridinium chlorochromate
 - Heat in the presence of Cu at 573 K
23. In a hypothetical reaction $X \longrightarrow Y$, the activation energy for the forward and the backward reactions are 15 and 9 kJ mol^{-1} respectively. The potential energy of X is 10 kJ mol^{-1} . Then
- threshold energy of the reaction is 25 kJ
 - the potential energy of Y is 16 kJ
 - heat of reaction is 6 kJ
 - the reaction is endothermic.

Numerical Value Type

24. The maximum covalency shown by Be is
25. For the Mg-Ag cell, how many times the difference between the EMF of the cell and its standard EMF will change if concentration of Mg^{2+} ions is changed from 0.1 M to 0.01 M and that of Ag^+ ions is changed from 0.5 M to 0.25 M?

mtg

ONLINE TEST SERIES

Practice Part Syllabus/ Full Syllabus
24 Mock Tests for

JEE Main

Now on your android Smart phones
with the same login of web portal.

Log on to test.pcmbtoday.com

26. In a *fcc* lattice of *X* and *Y*, *X* atoms are present at the corners while *Y* atoms are present at the face centres. If one of the *X* atom from a corner is replaced by monovalent *Z* atom, then the formula of compound is given as $X_a Y_b Z$. Here *a* is

Matrix Match Type

Understand carefully the following two reactions and answer the questions given below :

Reaction (i)

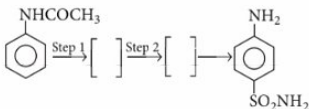

Reaction (ii)

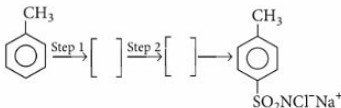

27. Which of the steps is common in the two reactions?
- 1st step
 - 2nd step
 - Both the steps
 - None of the steps
28. Which of the final products are medically important?
- Product from reaction (i)
 - Product from reaction (ii)
 - Product from both reactions
 - None of the above
29. Match the compounds given in Column I with their shapes in Column II.

Column I

- XeO_3
- $XeOF_4$
- BO_3^{3-}
- $I_3^- (aq)$

Column II

- Trigonal pyramidal
- Linear
- Square pyramidal
- Trigonal planar

A B C D

- P Q R S
- S P Q R
- P R S Q
- P S R Q

30. Match the reactions given in Column I with the steps involved in mechanism in Column II.

Column I

- Benzaldehyde reacts with methanal in presence of NaOH to give benzyl alcohol and sodium methanoate.
- Propanone reacts with $Ba(OH)_2$ to form 4-hydroxy-4-methylpentan-2-one.
- Iodoform is produced when butanone is treated with NaOI.
- Carboxylic acids containing α -hydrogen(s) on treatment with Br_2 in presence of red P give α -haloacids.

Column II

- Acidic nature of α -hydrogens
- Hydride transfer
- Halogenation
- Nucleophilic addition

A B C D

- Q, R P, Q R, S P, R
- Q, S P, S P, R, S P, R
- Q, S P, R, S P, R P, S
- P, Q Q, R R, S P, S



Keys are published in this issue. Search now!

SELF CHECK

No. of questions attempted
 No. of questions correct
 Marks scored in percentage

Check your score! If your score is

- | | | |
|-----------------|--------------------------|------------------------------------------------------------|
| > 90% | EXCELLENT WORK ! | You are well prepared to take the challenge of final exam. |
| 90-75% | GOOD WORK ! | You can score good in the final exam. |
| 74-60% | SATISFACTORY ! | You need to score more next time. |
| < 60% | NOT SATISFACTORY! | Revise thoroughly and strengthen your concepts. |

NCERT CORNER

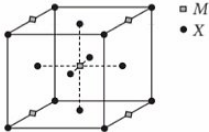

The questions given in this column have been prepared strictly on the basis of NCERT Chemistry, Papers of JEE(Main & Advanced) / NEET / AIIMS / JIPMER are drawn heavily from NCERT books. Practice Hard! All the best!!!

- Common salt obtained from sea-water contains 95% NaCl by mass. The approximate number of molecules present in 10.0 g of the salt is :
(a) 10^{21} (b) 10^{22} (c) 10^{23} (d) 10^{24}
- Which one of the following statements is not true regarding (+) lactose?
(a) (+)-Lactose, $C_{12}H_{22}O_{11}$ contains 8 -OH groups.
(b) On hydrolysis (+)-lactose gives equal amount of *D*(+)-glucose and *D*(+)-galactose.
(c) (+)-Lactose is a β -glycoside formed by the union of a molecule of *D*(+)-glucose and a molecule of *D*(+)-galactose.
(d) (+)-Lactose is a reducing sugar and does not exhibit mutarotation.
- A colourless solid (*X*) on heating evolved CO_2 and also gave a white residue, soluble in water. Residue also gave CO_2 when treated with dilute acid. (*X*) is
(a) Li_2CO_3 (b) $CaCO_3$
(c) $Ca(HCO_3)_2$ (d) $NaHCO_3$
- A compound M_pX_q has cubic close packing (*ccp*) arrangement of *X*. Its unit cell structure is shown below. The empirical formula of the compound is

(a) MX (b) MX_2 (c) M_2X (d) M_3X_{14}
- The orbital diagram in which Aufbau principle is violated is
(a) $\begin{array}{c} 2s \\ \uparrow\downarrow \end{array} \quad \begin{array}{c} 2p \\ \uparrow\downarrow \uparrow\downarrow \end{array}$ (b) $\begin{array}{c} 2s \\ \uparrow\downarrow \end{array} \quad \begin{array}{c} 2p \\ \uparrow\downarrow \uparrow\downarrow \uparrow\downarrow \end{array}$
(c) $\begin{array}{c} 2s \\ \uparrow\downarrow \end{array} \quad \begin{array}{c} 2p \\ \uparrow\downarrow \uparrow\downarrow \uparrow\downarrow \end{array}$ (d) $\begin{array}{c} 2s \\ \uparrow\downarrow \end{array} \quad \begin{array}{c} 2p \\ \uparrow\downarrow \uparrow\downarrow \uparrow\downarrow \end{array}$
- On addition of small amount of $KMnO_4$ to concentrated H_2SO_4 , a green oily compound is obtained which is highly explosive in nature. Identify the compound from the following.
(a) Mn_2O_7 (b) MnO_2
(c) $MnSO_4$ (d) Mn_2O_3
- The IUPAC name of the compound,

$$CH_3-\overset{\overset{CH_3}{|}}{CH}-\overset{\overset{CH_3}{|}}{CH}-CH(CH_2CH_2CH_2CH_3)_2$$
 is
(a) 1,1-dibutyl-2, 3-dimethylbutane
(b) 2, 4, 4-dibutyl-3, 3-dimethylbutane
(c) 5-(1, 2-dimethylpropyl)nonane
(d) 4-butyl-2, 3-dimethyloctane.
- On the basis of informations given below mark the correct option :
I. In bromoethane and chloroethane mixture, intermolecular interactions of *A-A* and *B-B* types are nearly same as *A-B* type interactions.
II. In ethanol and acetone mixture, *A-A* or *B-B* types intermolecular interactions are stronger than *A-B* type interactions.
III. In chloroform and acetone mixture, *A-A* or *B-B* types intermolecular interactions are weaker than *A-B* type interactions.
(a) Solutions (II) and (III) will follow Raoult's law.
(b) Solution (I) will follow Raoult's law.
(c) Solution (II) will show negative deviation from Raoult's law.
(d) Solution (III) will show positive deviation from Raoult's law.
- Following reaction occurs at $25^\circ C$,

$$2NO(g) + Cl_2(g) \rightleftharpoons 2NOCl(g)$$

$$1 \times 10^{-5} \text{ atm} \quad 1 \times 10^{-2} \text{ atm} \quad 1 \times 10^{-2} \text{ atm}$$
 ΔG° for the following reaction is
(a) - 45.65 kJ (b) - 28.53 kJ
(c) - 22.82 kJ (d) - 57.06 kJ

10. Treatment of acetaldehyde with ethyl magnesium bromide and subsequent hydrolysis gives
 (a) 1-butanol (b) 2-butanol
 (c) 1-propanol (d) *tert*-butanol.

11. The lowest first ionisation enthalpy would be associated with which of the following configurations?
 (a) $1s^2 2s^2 2p^6 3s^1$ (b) $1s^2 2s^2 2p^5$
 (c) $1s^2 2s^2 2p^6$ (d) $1s^2 2s^2 2p^6 3s^2 3p^2$

12. What kind of isomerism exists between $[\text{Cr}(\text{H}_2\text{O})_6]\text{Cl}_3$ (violet) and $[\text{Cr}(\text{H}_2\text{O})_5\text{Cl}]\text{Cl}_2 \cdot \text{H}_2\text{O}$ (greyish-green)?
 (a) Linkage isomerism (b) Solvate isomerism
 (c) Ionisation isomerism (d) Coordination isomerism

13. An organic compound weighing 0.15 g gave on Carius estimation, 0.12 g of AgBr. The percentage of Br in the compound will be close to
 (At. mass of Ag = 108, Br = 80)
 (a) 46.02% (b) 34.04% (c) 3.41% (d) 4.60%

14. Which of the following is the best leaving group (weakest conjugate base)?

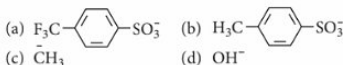

15. What is the minimum volume of water required to dissolve 1 g of calcium sulphate at 298 K?
 (Given : For calcium sulphate, $K_{sp} = 9.1 \times 10^{-6}$)
 (a) 3.02 L (b) 2.00 L
 (c) 2.56 L (d) 2.43 L

16. Small quantities of solution of compounds TX, TY and TZ are put into separate test tubes containing X, Y and Z solutions. TX does not react with any of these. TY reacts with both X and Z. TZ reacts with X. The decreasing order of oxidation of the anions X^- , Y^- , Z^- is
 (a) $\text{Y}^- > \text{Z}^- > \text{X}^-$ (b) $\text{Z}^- > \text{X}^- > \text{Y}^-$
 (c) $\text{Y}^- > \text{X}^- > \text{Z}^-$ (d) $\text{X}^- > \text{Z}^- > \text{Y}^-$

17. Which of the following statements are correct about CO_3^{2-} ?
 I. The hybridisation of central atom is sp^3 .
 II. Its resonance structures have one C—O single bond and two C=O double bonds.
 III. The average formal charge on each oxygen atom is 0.67 units.
 IV. All C—O bond lengths are equal.
 (a) I and II only (b) I and III only
 (c) III and IV only (d) II and IV only

18. Which of the following statements is not correct?
 (a) $\text{La}(\text{OH})_2$ is less basic than $\text{Lu}(\text{OH})_3$.
 (b) In lanthanide series, ionic radius of Ln^{3+} ions decreases.
 (c) La is actually an element of transition series rather than lanthanoid series.
 (d) Atomic radii of Zr and Hf are same because of lanthanoid contraction.
19. A narrow spectrum antibiotic is active against
 (a) either gram positive or gram negative bacteria
 (b) gram negative bacteria only
 (c) single organism or one disease
 (d) both gram positive and gram negative bacteria.

20. Increasing order of dissociation constant (K_a) of

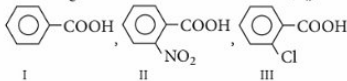



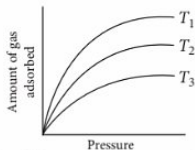

- is
 (a) $\text{I} < \text{II} < \text{III}$ (b) $\text{III} < \text{II} < \text{I}$
 (c) $\text{I} < \text{III} < \text{II}$ (d) $\text{II} < \text{III} < \text{I}$

21. From the molecular orbital theory, one can show that the bond order in F_2 molecule is
 (a) 2 (b) 1 (c) 3 (d) 4
22. The variation of amount of gas adsorbed per gram of adsorbent with pressure at different temperatures is given in the figure below :

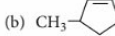

Which of the following is the correct relation?

- (a) $T_1 > T_2 > T_3$ (b) $T_2 > T_1 > T_3$
 (c) $T_3 > T_2 > T_1$ (d) $T_1 = T_2 = T_3$
23. The correct decreasing order of basic strength of the following species is
 H_2O , NH_3 , OH^- , NH_2^-
 (a) $\text{NH}_2^- > \text{OH}^- > \text{NH}_3 > \text{H}_2\text{O}$
 (b) $\text{OH}^- > \text{NH}_2^- > \text{H}_2\text{O} > \text{NH}_3$
 (c) $\text{NH}_3 > \text{H}_2\text{O} > \text{NH}_2^- > \text{OH}^-$
 (d) $\text{H}_2\text{O} > \text{NH}_3 > \text{OH}^- > \text{NH}_2^-$
24. The reaction of toluene with Cl_2 in presence of FeCl_3 gives X and reaction in presence of light gives Y. Thus, X and Y are

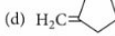
- (a) $X =$ benzyl chloride, $Y = m$ -chlorotoluene
 (b) $X =$ benzyl chloride, $Y = o$ -chlorotoluene
 (c) $X = m$ -chlorotoluene, $Y = p$ -chlorotoluene
 (d) $X = o$ - and p -chlorotoluene, $Y =$ trichloromethylbenzene
25. The volume of oxygen liberated at NTP from 10 mL of 20 volume H_2O_2 is
 (a) 250 mL (b) 300 mL
 (c) 150 mL (d) 200 mL
26. In the equation,
 $4M + 8CN^- + 2H_2O \xrightarrow{X} 4[M(CN)_2]^- + 4OH^-$,
 the metal M and reactant X are respectively
 (a) copper, air (b) iron, air
 (c) gold, oxygen (d) zinc, oxygen.
27. In the following reaction,
 $C_2H_5OC_2H_5 + [H] \xrightarrow{\text{Red P/HI}} 2X + H_2O$
 X is
 (a) ethane (b) ethylene
 (c) butane (d) propane.
28. The standard electrode potential for the half-cell reactions are
 $Zn^{2+} + 2e^- \longrightarrow Zn; E^\circ = -0.76 V$
 $Fe^{2+} + 2e^- \longrightarrow Fe; E^\circ = -0.44 V$
 The standard e.m.f. of the cell reaction,
 $Fe^{2+} + Zn \longrightarrow Zn^{2+} + Fe$ is
 (a) $-1.20 V$ (b) $+1.20 V$
 (c) $+0.32 V$ (d) $-0.32 V$
29. What is the correct order of reactivity of alcohols in the following reaction?
 $R-OH + HCl \xrightarrow{ZnCl_2} R-Cl + H_2O$
 (a) $1^\circ > 2^\circ > 3^\circ$ (b) $1^\circ < 2^\circ > 3^\circ$
 (c) $3^\circ > 2^\circ > 1^\circ$ (d) $3^\circ > 1^\circ > 2^\circ$
30. For the given reaction,
 CH_3 - $\xrightarrow[\text{heat}]{H_2SO_4}$ A (major), A is
 (a) CH_3 - (b) CH_3 -
 (c) CH_3 - (d) H_2C -
31. A student forgot to add the reaction mixture to the round bottom flask at $27^\circ C$ but instead he placed the flask on the flame. After a lapse of time, he realized his mistake, and using a pyrometer he found the temperature of the flask was $477^\circ C$. What fraction of air would have been expelled out?
 (a) 60% (b) 30% (c) 100% (d) 75%
32. Molar conductivities (Λ_m°) at infinite dilution of $NaCl$, HCl and CH_3COONa are 126.4, 425.9 and $91.0 S cm^2 mol^{-1}$ respectively. Λ_m° for CH_3COOH will be
 (a) $390.5 S cm^2 mol^{-1}$ (b) $425.5 S cm^2 mol^{-1}$
 (c) $180.5 S cm^2 mol^{-1}$ (d) $290.8 S cm^2 mol^{-1}$
33. Which one of the following statements is not true?
 (a) pH of drinking water should be between 5.5 – 9.5.
 (b) Concentration of D.O. below 6 ppm is good for the growth of fish.
 (c) Clean water should have a B.O.D. value of less than 5 ppm.
 (d) Oxides of S, N and C are the most widespread air pollutants.
34. In vulcanisation of rubber,
 (a) sulphur reacts to form a new compound
 (b) sulphur cross-links are introduced
 (c) sulphur forms a very thin protective layer over rubber
 (d) all statements are correct.
35. What is the correct order of decreasing stability of the following cations?
 I. $CH_3 - \overset{+}{C}H - CH_3$
 II. $CH_3 - \overset{+}{C}H - OCH_3$
 III. $CH_3 - \overset{+}{C}H - CH_2 - OCH_3$
 (a) II > I > III (b) II > III > I
 (c) III > I > II (d) I > II > III
36. $[AgI]/I^-$ colloidal sol can be coagulated by the addition of a suitable cation. The number of moles of $AgNO_3$, $Pb(NO_3)_2$ and $Fe(NO_3)_3$ respectively required to caugulate 1 mol of $[AgI]/I^-$ is
 (a) 1, 1, 1 (b) 1, 2, 3
 (c) $1, \frac{1}{2}, \frac{1}{3}$ (d) 6, 3, 2
37. Water softening by Clark's process uses
 (a) calcium bicarbonate (b) sodium bicarbonate
 (c) potash alum (d) calcium hydroxide.
38. Saponification of an ester (A) followed by neutralisation gives a compound (B), which gives violet colouration with $FeCl_3$. The ester (A) is
 (a) ethyl salicylate (b) ethyl acetate
 (c) ethyl benzoate (d) diethyl phthalate.
39. A solution having volume ' V ' at temperature ' T ' and pressure ' P ' is mixed with other solution with same volume ' V ', temperature ' T ' and pressure ' P '. The resulting solution after mixing both solutions

has volume 'V', temperature 'T' and pressure

- (a) $2P$ (b) $4P$ (c) $P/2$ (d) P

40. Which of the following compounds are chiral?

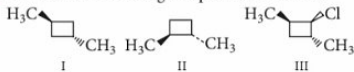

- (a) Only I and II (b) Only II and III
(c) Only I and III (d) Only III

41. Oxidation states of P in $H_4P_2O_5$, $H_4P_2O_6$ and $H_4P_2O_7$ respectively are

- (a) +3, +5, +4 (b) +5, +3, +4
(c) +5, +4, +3 (d) +3, +4, +5

42. $C_3H_6Cl_2$ on reaction with NaOH forms C_3H_6O , which gives yellow precipitate on heating with NaOH and I_2 . Thus, $C_3H_6Cl_2$ is

- (a) 1,1-dichloropropane (b) 1,2-dichloropropane
(c) 2,2-dichloropropane (d) 1,3-dichloropropane.

43. For the reactions,

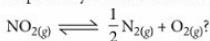
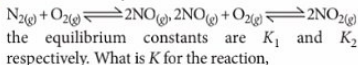

- (a) $\frac{1}{2K_1K_2}$ (b) $\frac{1}{4K_1K_2}$
(c) $\left[\frac{1}{K_1K_2}\right]^{1/2}$ (d) $\frac{1}{K_1K_2}$

44. Which of the following is the incorrect statement?

- (a) All halogens form oxyacids.
(b) All halogens show -1, +1, +3, +5, +7 oxidation states.
(c) Hydrofluoric acid forms KHF_2 and K_2F_2 and attacks glass.
(d) Oxidising power is in order $F_2 > Cl_2 > Br_2 > I_2$.

45. The formation of the oxide ion, $O_{2(g)}^{2-}$, from oxygen atom requires first an exothermic and then an endothermic step as shown below :

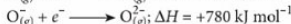
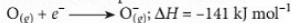

Thus, process of formation of $O_{2(g)}^{2-}$ in gas phase is unfavourable even though $O_{2(g)}^{2-}$ is isoelectronic with neon. It is due to the fact that

- (a) oxygen is more electronegative
(b) addition of electron in oxygen results in larger size of the ion
(c) electron repulsion outweighs the stability gained by achieving noble gas configuration

(d) O^- ion has comparatively smaller size than oxygen atom.

46. Titanium shows magnetic moment of 1.73 B.M. in its compound. What is the oxidation number of Ti in the compound?

- (a) +1 (b) +4 (c) +3 (d) +2

47. Heat of formation of acetylene is $x \text{ J mol}^{-1}$ and that of ethylene is $y \text{ J mol}^{-1}$. What is the heat of hydrogenation of acetylene?

- (a) $(x - y) \text{ J mol}^{-1}$ (b) $(x - 2y) \text{ J mol}^{-1}$
(c) $(y - 2x) \text{ J mol}^{-1}$ (d) $(y - x) \text{ J mol}^{-1}$

48. Pure benzene freezes at 5.42°C . A solution of 0.223 g of phenylacetic acid ($C_6H_5CH_2COOH$) in 4.4 g of benzene ($K_f = 5.12 \text{ K kg mol}^{-1}$) freezes at 4.47°C . From this observation, one can conclude that

- (a) phenylacetic acid exists as such in benzene
(b) phenylacetic acid undergoes partial ionisation in benzene
(c) phenylacetic acid undergoes complete ionisation in benzene
(d) phenylacetic acid dimerises in benzene.

49. If the photon of the wavelength 150 pm strikes an atom and one of its inner bound electron is ejected out with a velocity of $1.5 \times 10^7 \text{ m s}^{-1}$, calculate the energy with which it is bound to the nucleus.

- (a) $6.26 \times 10^{-3} \text{ eV}$ (b) $12.25 \times 10^{-3} \text{ eV}$
(c) $7.63 \times 10^3 \text{ eV}$ (d) $9.11 \times 10^3 \text{ eV}$

50. For a certain reaction,

$nA \longrightarrow \text{Products}$, a plot of C^{-1} (where C represents molar concentration of A) vs time t is as shown in the figure. Which of the following is not correct?

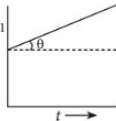

- (a) Rate = $k[A]^2$
(b) Slope, $\tan \theta =$ Rate constant, k
(c) Intercept on C^{-1} axis = $1/C_0$
(d) Units of rate constant = $L^2 \text{ mol}^{-2} \text{ s}^{-1}$

SOLUTIONS

1. (c) : 10 g of the salt will contain = 9.5 g NaCl
1 mole, i.e., 58.5 g of NaCl contains 6.023×10^{23} molecules of NaCl
 \therefore 9.5 g of NaCl will contain
$$\frac{6.023 \times 10^{23}}{58.5} \times 9.5 \approx 9.5 \times 10^{23}$$
 molecules of NaCl
2. (d) : (+)-Lactose is a reducing sugar and shows mutarotation.

39. (d): Total volume = $V_1 + V_2$

Let the total pressure be P and partial pressures will be p'_1 and p'_2 respectively in the resultant solution.

Applying Boyle's law,

$$p'_1(V_1 + V_2) = p_1 V_1 \quad \dots(i)$$

$$p'_2(V_1 + V_2) = p_2 V_2 \quad \dots(ii)$$

By adding (i) and (ii), we get,

$$p'_1 + p'_2 = \frac{p_1 V_1}{V_1 + V_2} + \frac{p_2 V_2}{V_1 + V_2} = \frac{p_1 V_1 + p_2 V_2}{V_1 + V_2}$$

$$p_1 = p_2 = P \text{ and } V_1 = V_2 = V$$

$$\text{So, } p'_1 + p'_2 = P$$

40. (b):

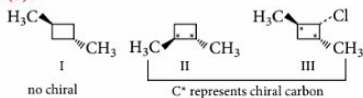

Thus, II and III are chiral compounds.

41. (d): $H_4P_2O_5: 4 + 2x - 10 = 0 \Rightarrow x = +3$

$$H_4P_2O_6: 4 + 2x - 12 = 0 \Rightarrow x = +4$$

$$H_4P_2O_7: 4 + 2x - 14 = 0 \Rightarrow x = +5$$

42. (c): C_3H_6O gives yellow ppt. on heating with

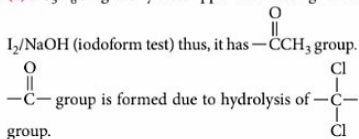

Thus, $C_3H_6Cl_2$ is

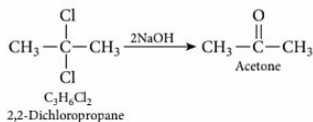

43. (c): $N_{2(g)} + O_{2(g)} \rightleftharpoons 2NO_{(g)}; K_1$

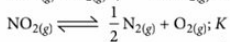

$$K_1 = \frac{[NO]^2}{[N_2][O_2]}; K_2 = \frac{[NO_2]^2}{[NO]^2[O_2]}$$

$$K = \frac{[N_2]^{1/2}[O_2]}{[NO_2]} = \sqrt{\frac{[N_2][O_2]}{[NO]^2} \times \frac{[NO]^2[O_2]}{[NO_2]^2}}$$

$$K = \sqrt{\frac{1}{K_1 K_2}}$$

44. (b): Fluorine shows only -1 and +1 oxidation states.

45. (c)

46. (c): μ_{eff} value of 1.73 B.M. corresponds to one unpaired electron.

Electronic configuration of Ti = $[Ar] 3d^2 4s^2$

Electronic configuration of Ti^{3+} = $[Ar] 3d^1$

47. (d): $CH \equiv CH + H_2 \longrightarrow CH_2 = CH_2; \Delta H = ?$

$$\Delta H = \Delta H_f(CH_2 = CH_2) - \Delta H_f(CH \equiv CH) - \Delta H_f(H_2)$$

$$= y - x - 0 = (y - x) \text{ J mol}^{-1}$$

48. (d): $\Delta T_f = T_f^o - T_f = 5.42 - 4.47 = 0.95^\circ C$

$$\text{Molality of solvent, } m = \frac{0.223}{136} \times \frac{1000}{4.4} = 0.373 \text{ m}$$

(Molar mass of phenylacetic acid = 136 g/mol)

$$\Delta T_f = i \cdot K_f \cdot m$$

$$i = \frac{\Delta T_f}{K_f m} = \frac{0.95}{5.12 \times 0.373} = 0.497 \approx 0.5$$

It means phenylacetic acid undergoes dimerisation in benzene.

49. (c): Photon of wavelength = 150 pm = 150×10^{-12} m

$$\text{Energy of photon } (E) = \frac{hc}{\lambda}$$

$$= \frac{6.626 \times 10^{-34} \times 3 \times 10^8}{150 \times 10^{-12}} = 0.1325 \times 10^{-14} \text{ J}$$

$$= 13.25 \times 10^{-16} \text{ J}$$

$$K.E. \text{ of the ejected electron} = \frac{1}{2} mv^2$$

$$= \frac{1}{2} \times 9.11 \times 10^{-31} \times (1.5 \times 10^7)^2 = 1.025 \times 10^{-16} \text{ J}$$

Energy with which the electron is bound to the nucleus

$$= (13.25 \times 10^{-16} - 1.025 \times 10^{-16}) \text{ J} = 12.225 \times 10^{-16} \text{ J}$$

$$= \frac{12.225 \times 10^{-16}}{1.602 \times 10^{-19}} \approx 7.63 \times 10^3 \text{ eV}$$

[$\therefore 1.602 \times 10^{-19} \text{ J} = 1 \text{ eV}$]

50. (d): For 2^{nd} order reaction,

$$k = \frac{1}{t} \left\{ \frac{1}{[A]} - \frac{1}{[A]_0} \right\} \quad \text{or} \quad \frac{1}{[A]} = kt + \frac{1}{[A]_0}$$

Hence, plot of $1/[A]$ vs t is linear with slope = k and intercept = $1/[A]_0$. Therefore, (a), (b), (c) are correct. Units of k for 2^{nd} order reaction = $L \text{ mol}^{-1} \text{ s}^{-1}$.



EXAM PREP



Useful for Medical/Engg. Entrance Exams

- Choose the correct match from the following.
(a) Emulsion-smoke (b) Gel-butter
(c) Aerosol-hair cream (d) Sol-whipped cream
- Given table shows that the bond dissociation energies (E_{diss}) for single covalent bonds of carbon (C) atoms with elements A, B, C and D. Which of these elements has the smallest atoms?

Bond	E_{diss} (kJ mol ⁻¹)
C - A	240
C - B	328
C - C	276
C - D	485

- (a) A (b) B (c) C (d) D
- Consider the following reactions of two metals A and B:
 $\text{ACl}_2 + \text{BCl}_2 \longrightarrow \text{ACl}_4 + \text{B}\downarrow$
 (Excess)
 $\text{BO} \xrightarrow{\text{Heat}} \text{B} + 1/2\text{O}_2$
 An ore of B is
 (a) cinnabar (b) azurite
 (c) galena (d) siderite.
 - Which of the following is *s*-butylphenylvinyl methane?

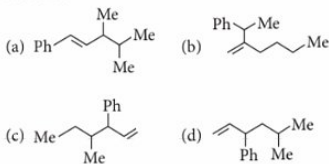

- In which of the following pairs, both the hydrides are not of the same type?
(a) $\text{LaH}_3, \text{TiH}_2$ (b) $\text{CH}_4, \text{H}_2\text{S}$
(c) NaH, CaH_2 (d) $\text{BaH}_2, \text{SiH}_4$
- Which of the following molecules has two types of FXF angles (X = S, Xe, C)?
(a) SF_4 (b) XeF_4 (c) SF_6 (d) CF_4
- Ammonia under a pressure of 15 atm at 27 °C is heated to 347 °C in a closed vessel in the presence of a catalyst. Under the conditions, NH_3 is partially decomposed according to the equation,
 $2\text{NH}_3 \rightleftharpoons \text{N}_2 + 3\text{H}_2$
 The vessel is such that the volume remains constant whereas pressure increases to 50 atm. What is the percentage of NH_3 actually decomposed?
 (a) 65% (b) 61.3%
 (c) 62.5% (d) 64%
- Which of the following is a correct set of reactants for the preparation of 1-methoxy-4-nitrobenzene?

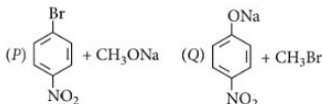

- (a) P (b) Q
(c) Both P and Q (d) None of these
- The value of maximum percentage of available chlorine of bleaching powder ($\text{CaOCl}_2 \cdot \text{H}_2\text{O}$) is
(a) 35 (b) 40 (c) 45 (d) 49
 - For the given hypothetical reaction mechanism,
 $\text{A} \xrightarrow{\text{I}} \text{B} \xrightarrow{\text{II}} \text{C} \xrightarrow{\text{III}} \text{D} \xrightarrow{\text{IV}} \text{E}$
 the data is given as :

Species formed	Rate of its formation
B	0.002 mol/h per mole of A
C	0.030 mol/h per mole of B
D	0.011 mol/h per mole of C
E	0.120 mol/h per mole of D

The rate determining step for the reaction is

- (a) step I (b) step II
(c) step III (d) step IV.

11. Based on lattice energy and other facts, which one of the following alkali metal chlorides is expected to have highest melting point?

- (a) LiCl (b) NaCl (c) KCl (d) RbCl

12. A solution containing one mole per litre of each $\text{Cu}(\text{NO}_3)_2$, AgNO_3 , $\text{Hg}_2(\text{NO}_3)_2$ and $\text{Mg}(\text{NO}_3)_2$, is being electrolysed by using inert electrodes. The values of standard electrode potentials in volts (reduction potentials) are $\text{Ag}^+/\text{Ag} = +0.80$, $\text{Hg}_2^{2+}/2\text{Hg} = +0.79$, $\text{Cu}^{2+}/\text{Cu} = +0.34$, $\text{Mg}^{2+}/\text{Mg} = -2.37$. The sequence of deposition of metals on the cathode is

- (a) Ag, Hg, Cu, Mg (b) Mg, Cu, Hg, Ag
(c) Ag, Hg, Cu (d) Cu, Hg, Ag

13. In a reaction vessel, 100 g H_2 and 100 g Cl_2 are mixed and suitable conditions are provided for the following reaction,

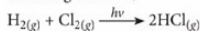

Quantum yield of this reaction, ϕ is 10^5 .

The limiting reagent in this reaction is

- (a) H_2 (b) Cl_2
(c) both (a) and (b) (d) cannot be predicted.
14. 8 g of a radioactive substance is reduced to 0.5 g after 1 hour. The $t_{1/2}$ of the radioactive substance is
- (a) 15 min (b) 30 min
(c) 45 min (d) 10 min

15. An alkane with molecular formula, C_6H_{14} reacts with chlorine in the presence of light and heat to give two constitutionally isomeric monochlorides of molecular formula, $\text{C}_6\text{H}_{13}\text{Cl}$. What will be the starting alkane?

- (a) *n*-Hexane (b) 2,2-Dimethylbutane
(c) 2,3-Dimethylbutane (d) 3-Methylpentane

16. Which of the following reactions is correctly related to extraction of Pb from galena?

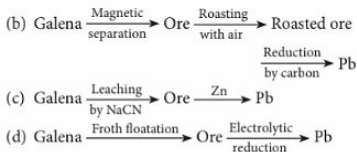
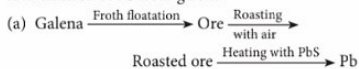

17. What will be the product in the following reaction?

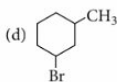
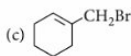
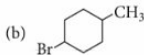
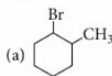
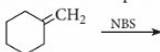

18. In chromite ore, the oxidation number of iron and chromium are respectively

- (a) +3, +2 (b) +3, +6
(c) +2, +6 (d) +2, +3

19. For an octahedral complex, which of the following *d*-electron configurations will give maximum CFSE?

- (a) High spin d^6 (b) Low spin d^5
(c) Low spin d^4 (d) High spin d^7

20. 0.395 g of an organic compound by Carius method for the estimation of S gave 0.582 g of BaSO_4 . What is the percentage of S in the compound?

- (a) 20.23% (b) 35.62%
(c) 12.24% (d) 40.65%

21. Correct decreasing order of reactivity in Williamson ether synthesis of the following is

- I. $\text{Me}_3\text{CCH}_2\text{Br}$ II. $\text{CH}_3\text{CH}_2\text{CH}_2\text{Br}$
III. $\text{CH}_2=\text{CHCH}_2\text{Cl}$ IV. $\text{CH}_3\text{CH}_2\text{CH}_2\text{Cl}$
(a) III > II > IV > I (b) I > II > IV > III
(c) II > III > IV > I (d) I > III > II > IV

22. Air contains 20% oxygen by volume. What will the theoretical volume of air which will be required for burning completely 500 m^3 of acetylene gas? (All volumes are measured under the same conditions of temperature and pressure.)

- (a) 1250 m^3 (b) 6250 m^3
(c) 1550 m^3 (d) 5250 m^3

23. Oxidation of acetaldehyde with selenium dioxide gives

- (a) ethanoic acid (b) methanoic acid
(c) glyoxal (d) oxalic acid.

24. How long would it take a radiowave of frequency, $6 \times 10^3 \text{ s}^{-1}$ to travel from Mars to the Earth, a distance of $8 \times 10^7 \text{ km}$?

- (a) 2 min 66 s (b) 4 min 26 s
(c) 3 min 22 s (d) 5 min 44 s

25. Proteins are found to have two different types of secondary structures viz. α -helix and β -pleated sheet structure. α -Helix structure of protein is made up of

- (a) peptide bonds
(b) van der Waals forces
(c) hydrogen bonds
(d) dipole-dipole interactions.

26. Select correct systematic diagram which is related to second I.E. of Mg, Al, Si.

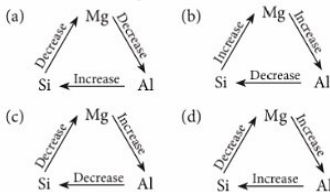

27. An aqueous solution of glucose is made by dissolving 10 g of glucose ($\text{C}_6\text{H}_{12}\text{O}_6$) in 90 g of water at 303 K. If the vapour pressure of pure water at 303 K is 32.8 mm Hg, what would be the vapour pressure (in mm Hg) of the solution?

- (a) 32.8 (b) 35.5 (c) 31.8 (d) 32.44

28. Which of the following statements is not correct?

- (a) Some disinfectants can be used as antiseptic at low concentration.
(b) Sulphadiazine is a synthetic antibacterial.
(c) Pheromones provide chemical means of establishing communication.
(d) Norethindrone is a pheromone.

29. Which of the following is in accordance to inert pair effect?

- (i) SnCl_2 acts as a reducing agent.
(ii) SnCl_4 acts as an oxidising agent.
(iii) SnO_2 is amphoteric.
(iv) PbO_2 is an oxidant.
(v) CCl_2 is unstable but PbCl_2 is stable.

- (a) (i), (iv), (v)
(b) (iv), (v)
(c) (i), (ii), (iii), (iv) and (v)
(d) (i), (ii) and (iii)

30. A mineral of titanium (perovskite) is found to contain calcium ions at the corners, oxygen atoms at the face centres and titanium atoms at the centre of the cube. The oxidation state of titanium in the mineral will be

- (a) +1 (b) +3 (c) +4 (d) +2

31. Compound A ($\text{C}_7\text{H}_8\text{O}$) is insoluble in NaHCO_3 solution but dissolves in sodium hydroxide and gives a characteristic colour with aqueous ferric chloride solution. When treated with bromine, A forms compound B with molecular formula, $\text{C}_7\text{H}_5\text{OBr}_3$. Give the structural formula of A.

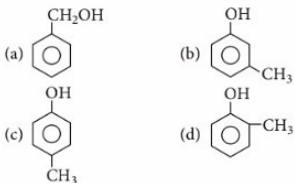

32. Highest oxidation state of manganese in fluoride is +4 (MnF_4) but highest oxidation state in oxides is +7 (Mn_2O_7) because





- (a) fluorine is more electronegative than oxygen
(b) fluorine does not possess *d*-orbitals
(c) fluorine stabilises lower oxidation state
(d) in covalent compounds fluorine can form single bond only while oxygen forms double bond.

33. Which of the following chemicals are used to manufacture methyl isocyanate that caused "Bhopal Gas Tragedy"?

- (i) Methylamine (ii) Phosgene
(iii) Phosphine (iv) Dimethylamine
(a) (i) and (ii) (b) (iii) and (iv)
(c) (i) and (iii) (d) (ii) and (iv)

34. In the solvolysis of 3-methyl-3-bromohexane, which of the following statements is wrong?

- (a) It involves carbocation intermediate.
(b) The intermediate involves sp^2 -carbon.
(c) The rate of reaction depends upon 3-methyl-3-bromohexane concentration.
(d) It involves inversion of configuration.

35. If two molecules each of A and B have mass 100 kg and 64 kg respectively and rate of diffusion of A is 12×10^{-3} , then the value rate of diffusion of B is
 (a) 15×10^{-3} (b) 64×10^{-3}
 (c) 5×10^{-3} (d) 46×10^{-3}
36. What will be the correct order for the wavelengths of absorption in the visible region for the following $[\text{Ni}(\text{NO}_2)_6]^{4-}$, $[\text{Ni}(\text{NH}_3)_6]^{2+}$, $[\text{Ni}(\text{H}_2\text{O})_6]^{2+}$?
 I II III
 (a) I > II > III (b) III > II > I
 (c) II > I > III (d) III > I > II
37. Which of the following reactions does not give N-ethyl cyclopentyl amine as a major product?
 (a)  + $\text{CH}_3\text{CHO} \xrightarrow{\text{H}_2/\text{Pt}}$
 (b)  + $\text{CH}_3\text{CH}_2\text{NH}_2 \xrightarrow{\text{H}_2/\text{Pt}}$
 (c)  $\xrightarrow[\text{Pyridine}]{\text{CH}_3\text{CH}_2\text{NH}_2}$ $\xrightarrow[\text{(ii) H}_2\text{O}]{\text{(i) LiAlH}_4, \text{Et}_2\text{O}}$
 (d)  $\xrightarrow[\text{Pyridine}]{\text{CH}_3\text{COCl}}$ $\xrightarrow[\text{(ii) H}_2\text{O}]{\text{(i) LiAlH}_4}$
38. The entropy change involved in the isothermal reversible expansion of 2 moles of an ideal gas from a volume of 10 dm^3 to a volume of 100 dm^3 at 27°C is
 (a) $35.8 \text{ J mol}^{-1} \text{ K}^{-1}$ (b) $32.3 \text{ J mol}^{-1} \text{ K}^{-1}$
 (c) $42.3 \text{ J mol}^{-1} \text{ K}^{-1}$ (d) $38.3 \text{ J mol}^{-1} \text{ K}^{-1}$
39. Which of the following is not true for low density polythene?
 (a) Tough
 (b) Hard
 (c) Poor conductor of electricity
 (d) Highly branched structure
40. The Nobel prize in Chemistry in 2005 was awarded for the work
 (a) concerning the reduction of hazardous wastes in creating new chemicals
 (b) concerning the formation and decomposition of ozone
 (c) concerning the recycling of CFCs
 (d) concerning the climate change.
41. Critical temperature values of H_2O , NH_3 , CO_2 and O_2 are 647 K, 405.6 K, 304.10 K and 154.2 K respectively. If the cooling starts from 500 K to their critical temperature, the gas that liquefies first is
 (a) H_2O (b) NH_3 (c) CO_2 (d) O_2
42. Which of the following reactions of glucose can be explained by its cyclic structure?
 (a) Glucose forms pentaacetate.
 (b) Glucose reacts with hydroxyl amine to form an oxime.
 (c) Pentaacetate of glucose does not react with hydroxyl amine.
 (d) Glucose is oxidised by nitric acid to gluconic acid.
43. Which of the following lanthanides shows II and III common oxidation states?
 (a) La (b) Nd (c) Ce (d) Eu
44. E_1 , E_2 and E_3 are the emf values of the following three galvanic cells respectively:
 (i) $\text{Zn}_{(s)} | \text{Zn}^{2+} (0.1 \text{ M}) || \text{Cu}^{2+} (1 \text{ M}) | \text{Cu}_{(s)}$
 (ii) $\text{Zn}_{(s)} | \text{Zn}^{2+} (1 \text{ M}) || \text{Cu}^{2+} (1 \text{ M}) | \text{Cu}_{(s)}$
 (iii) $\text{Zn}_{(s)} | \text{Zn}^{2+} (1 \text{ M}) || \text{Cu}^{2+} (0.1 \text{ M}) | \text{Cu}_{(s)}$
 Which of the following is correct?
 (a) $E_2 > E_1 > E_3$ (b) $E_1 > E_2 > E_3$
 (c) $E_3 > E_1 > E_2$ (d) $E_3 > E_2 > E_1$
45. Polyethylene glycol is used in the preparation of which type of detergents?
 (a) Cationic detergents (b) Anionic detergents
 (c) Non-ionic detergents (d) Soaps
46. K_p/K_c for the reaction,
 $\text{CO}_{(g)} + \frac{1}{2} \text{O}_{2(g)} \rightleftharpoons \text{CO}_{2(g)}$ will be
 (a) 1 (b) RT
 (c) $1/\sqrt{RT}$ (d) $(RT)^{1/2}$
47. The best explanation for the solubility of MnS in dil. HCl is that
 (a) solubility product of MnCl_2 is less than that of MnS
 (b) concentration of Mn^{2+} is lowered by the formation of complex ions with chloride ions
 (c) concentration of sulphide ions is lowered by oxidation to free sulphur
 (d) concentration of sulphide ions is lowered by formation of the weak acid H_2S .
48. A 0.02 M solution of pyridinium hydrochloride has $\text{pH} = 3.44$. The value of the ionisation constant of pyridine, is

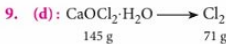

$$\% \text{ of available chlorine} = \frac{71}{145} \times 100 = 49$$

10. (a): As step I is the slowest, hence, it is the rate determining step.

11. (b): On the basis of lattice energy, the melting point of alkali metal chlorides is expected to decrease down the alkali metals group as lattice energy decreases with the increase of the atomic number. However, LiCl has covalent character due to very small size of Li^+ ion. Hence, melting point of NaCl is highest amongst the given alkali metal chlorides.

12. (c): A cation having highest reduction potential will be reduced first and so on. However, Mg^{2+} in aqueous solution will not be reduced as $E^\circ_{\text{Mg}^{2+}/\text{Mg}} < E^\circ_{\text{H}_2\text{O}/\frac{1}{2}\text{H}_2 + \text{OH}^-}$. Thus, water would be reduced instead of Mg^{2+} .

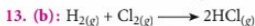

$$\text{Moles of } \text{H}_2(\text{g}) = \frac{100}{2} = 50$$

$$\text{Moles of } \text{Cl}_2(\text{g}) = \frac{100}{71} = 1.04$$

As H_2 and Cl_2 reacts in 1 : 1 mole ratio, hence Cl_2 is a limiting agent as it is present in lesser amount.

14. (a): $N_0 = 8 \text{ g}$, $N_t = 0.5 \text{ g}$ and $t = 1 \text{ hr} = 60 \text{ min}$

$$t = \frac{2.303 \times t_{1/2} \log \frac{N_0}{N_t}}{0.693} \quad \left(\because k = \frac{0.693}{t_{1/2}} \right)$$

$$60 = \frac{2.303 \times t_{1/2} \log \frac{8}{0.5}}{0.693}$$

$$60 = \frac{2.303 \times t_{1/2}}{0.693} \times 1.204$$

$$\Rightarrow t_{1/2} = 14.99 \approx 15 \text{ min}$$

15. (c):

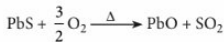
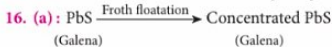
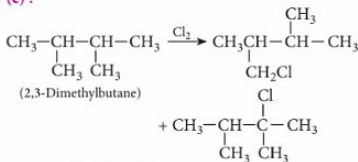

17. (c): Mechanism of allylic bromination is

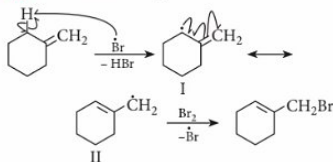

Since endocyclic (within ring) double bond (as in radical, II) is more stable than exocyclic (outside ring) double bond (as in radical I), therefore, initially formed less stable free radical (I) gets converted into the more stable free radical (II) which then reacts with Br_2 to give the product.

18. (d): Chromite ore is FeCr_2O_4 .

Oxidation state of Fe in FeCr_2O_4 is +2.

Let oxidation state of Cr be x in FeCr_2O_4 .

$$2 + 2x + 4(-2) = 0$$

$$2x = 6 \Rightarrow x = 3$$

19. (b): (a) High spin d^6 ; $t_{2g}^4 e_g^2$

$$\text{CFSE} = (+0.6 \times 2 - 0.4 \times 4)\Delta_0 = -0.4\Delta_0$$

(b) Low spin d^5 ; t_{2g}^5
 $\text{CFSE} = (+0.6 \times 0 - 0.4 \times 5)\Delta_0 = -2.0\Delta_0$

(c) Low spin d^4 ; t_{2g}^4
 $\text{CFSE} = (+0.6 \times 0 - 0.4 \times 4)\Delta_0 = -1.6\Delta_0$

(d) High spin d^7 ; $t_{2g}^5 e_g^2$
 $\text{CFSE} = (+0.6 \times 2 - 0.4 \times 5)\Delta_0 = -0.8\Delta_0$

Magnitude of CFSE is maximum for low spin d^5 complex.

20. (a): 233 g of BaSO_4 contains = 32 g of S

$$\therefore 0.582 \text{ g of } \text{BaSO}_4 \text{ will contain} = \frac{32}{233} \times 0.582$$

$$= 0.0799 \text{ g of S}$$

$$\% \text{ S} = \frac{0.0799}{0.395} \times 100 = 20.23\%$$

21. (c): C—Br bond is weaker than C—Cl bond, therefore, alkyl bromide (II) reacts faster than alkyl chlorides (III) and (IV). Since $\text{CH}_2=\text{CH}-$ is electron withdrawing while CH_3CH_2- is electron donating, therefore, $-\text{CH}_2-$ in III has more +ve charge than in IV.

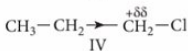
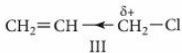

In other words, nucleophilic attack occurs faster on III than on IV. Further, since Williamson synthesis occurs by S_N2 mechanism, therefore, due to steric hindrance, neopentyl bromide (I) is the least reactive. Thus, the decreasing order of reactivity is: $\text{II} > \text{III} > \text{IV} > \text{I}$

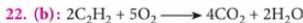

C_2H_2	O_2	CO_2	H_2O
2 vol.	5 vol.	4 vol.	2 vol.
1 vol	5/2 vol	2 vol	1 vol
500 m^3	$5/2 \times 500 \text{ m}^3$	$2 \times 500 \text{ m}^3$	$1 \times 500 \text{ m}^3$
500 m^3	1250 m^3	1000 m^3	500 m^3

Thus, 1250 m^3 oxygen is required for burning 500 m^3 of acetylene. But the percentage of oxygen in air is 20% only.

$$\therefore \text{Volume of air required} = 1250 \times \frac{100}{20} = 6250 \text{ m}^3$$

23. (c)

24. (b): All radiations in vacuum travel with the same speed, i.e., $3 \times 10^8 \text{ m s}^{-1}$

Distance to be travelled from Mars to the Earth = $8 \times 10^7 \text{ km} = 8 \times 10^7 \times 10^3 \text{ m}$ ($1 \text{ km} = 10^3 \text{ m}$)

$$\therefore \text{Time taken} = \frac{8 \times 10^7 \times 10^3}{3 \times 10^8} = 2.66 \times 10^2 \text{ s}$$

$$= 4 \text{ min } 26 \text{ s}$$

25. (c)



Order of second I.E. is $\text{Al}^+ > \text{Si}^+ > \text{Mg}^+$

27. (d): According to Raoult's law, vapour pressure of the solution containing non-volatile solute:

$$p = p_A^\circ x_A$$

where, p_A° = vapour pressure of pure water and x_A is the mole fraction of water.

$$p_A^\circ = 32.8 \text{ mm Hg}$$

$$\text{Moles of water} = \frac{90}{18} = 5$$

$$\text{Moles of glucose} = \frac{10}{180} = 0.0556$$

$$\text{Mole fraction of water, } x_A = \frac{5.0}{5.0 + 0.0556} = 0.989$$

$$\text{Vapour pressure of solution} = 32.8 \times 0.989$$

$$= 32.44 \text{ mm Hg}$$

28. (d): Norethindrone is not a pheromone. It is a progestin hormone. It is used for treating certain menstrual and uterine problems.

29. (b): Inert pair effect explains the stability of +2 oxidation state in lower elements of carbon family.

30. (c): No. of Ca atoms per unit cell

$$= 8 (\text{corners}) \times \frac{1}{8} = 1$$

$$\text{O atoms per unit cell} = 6 (\text{face centres}) \times \frac{1}{2} = 3$$

Ti atoms per unit cell = 1

\therefore Formula of mineral = CaTiO_3

Suppose oxidation state of Ti is x ,

$$+2 + x + 3(-2) = 0 \quad \text{or } x = +4$$

31. (b): Compound A gives characteristic colour with FeCl_3 solution, so it has a phenolic group. A forms tribromoproduct, thus it is *meta*-cresol.

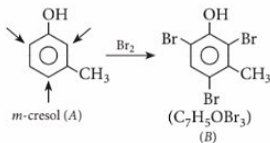

32. (d)

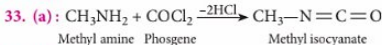

34. (d): S_N2 mechanism involves retention of configuration.

35. (a): $m_A = \left(\frac{100}{2}\right) \text{ kg/molecule}$

$$m_B = \left(\frac{64}{2}\right) \text{ kg/molecule}$$

Rate of diffusion, $r_A = 12 \times 10^{-3}$ and $r_B = ?$

According to Graham's law of diffusion,

$$\frac{r_A}{r_B} = \sqrt{\frac{d_B}{d_A}} = \sqrt{\frac{M_B}{M_A}}$$

M_B and M_A are molar masses of B and A respectively.

$$\Rightarrow \frac{r_A}{r_B} = \sqrt{\frac{(m_B \times N_A)}{(m_A \times N_A)}}$$

$$\frac{r_A}{r_B} = \sqrt{\frac{64/2}{100/2}} = \sqrt{\frac{64}{100}} = \frac{8}{10} = 0.8$$

$$\text{or } \frac{12 \times 10^{-3}}{r_B} = 0.8 \Rightarrow r_B = 15 \times 10^{-3}$$

36. (b): The order of ligand strength in the spectrochemical series is



Energy absorbed will be in the order :



Since $\lambda \propto 1/E$ ($E = hc/\lambda$), the wavelengths of light absorbed will be in the order :



37. (c)

38. (d): For isothermal reversible expansion of an ideal gas,

$$\Delta S = nR \ln \frac{V_2}{V_1} = 2 \times 8.314 \times 2.303 \log \frac{100}{10} \\ = 38.3 \text{ J mol}^{-1} \text{ K}^{-1}$$

39. (b)

40. (a): Nobel prize in Chemistry in 2005 was awarded to Yves Chauvin, Robert H. Grubbs and Richard R. Schrock for the development of the metathesis method in organic chemistry which represents a great step forward for green chemistry, reducing potentially hazardous wastes through smarter production.

41. (b): Since the cooling starts from 500 K, so water is not under consideration. As it is much easier to achieve 405.6 K from 500 K so, NH_3 will get liquefied first.

42. (c): Due to absence of free —OH group at C_1 , cyclic structure of glucose pentaacetate cannot revert to open chain aldehyde form and hence, cannot form an oxime.

43. (d)

$$44. \text{(b): } E_{\text{cell}} = E_{\text{cell}}^\circ - \frac{0.0591}{n} \log \left[\frac{\text{Zn}^{2+}}{\text{Cu}^{2+}} \right]$$

$$E_1 = E_{\text{cell}}^\circ - \frac{0.0591}{2} \log \frac{0.1}{1} \\ = E_{\text{cell}}^\circ + \frac{0.0591}{2}$$

$$E_2 = E_{\text{cell}}^\circ - \frac{0.0591}{2} \log \frac{1}{1} = E_{\text{cell}}^\circ$$

$$E_3 = E_{\text{cell}}^\circ - \frac{0.0591}{2} \log \frac{1}{0.1} = E_{\text{cell}}^\circ - \frac{0.0591}{2}$$

$$\therefore E_1 > E_2 > E_3$$

45. (c)

$$46. \text{(c): } K_f/K_c = (RT)^{\Delta n_g} = (RT)^{-1/2}$$

47. (d): It is a characteristic property of group IV radicals, concentration of sulphide ions is lowered by formation of the weak acid, H_2S .

48. (c): $\text{C}_6\text{H}_5\text{N}^+\text{HCl}^- + \text{H}_2\text{O} \rightleftharpoons \text{C}_6\text{H}_5\text{N}^+\text{HOH}^- + \text{HCl}$
(Solution is acidic due to hydrolysis)

As this is a salt of strong acid and weak base, hence,

$$\text{pH} = 7 - \frac{1}{2} (\text{p}K_b + \log C)$$

$$3.44 = 7 - \frac{\text{p}K_b + \log 0.02}{2}$$

$$\text{p}K_b = 8.82 = -\log K_b$$

$$\log K_b = -8.82 = \bar{9}.18$$

$$K_b = \text{antilog } \bar{9}.18 = 1.5 \times 10^{-9}$$

49. (b): $\overset{\ominus}{\underset{\text{H}}{\text{N}}}$ group due to +R (or +M) effect is always

o- and *p*-directing in nature while $\overset{\ominus}{\underset{\text{O}}{\text{C}}}=\text{O}$ is a

meta-director. $\overset{\ominus}{\underset{\text{H}}{\text{N}}}$ group has precedence over

$\overset{\ominus}{\underset{\text{O}}{\text{C}}}=\text{O}$ group.

50. (a): Given :

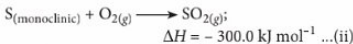
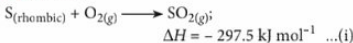

On subtracting equation (ii) from equation (i), we get

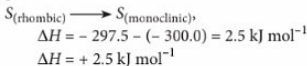

Thus, for the transformation of one gram atom of rhombic sulphur into monoclinic sulphur, 2.5 kJ mol⁻¹ of heat is absorbed.



YOU ASK WE ANSWER

Do you have a question that you just can't get answered?

Use the vast expertise of our mtg team to get to the bottom of the question. From the serious to the silly, the controversial to the trivial, the team will tackle the questions, easy and tough.

The best questions and their solutions will be printed in this column each month.

Q1. Can the stains of mustard oil be removed using potassium permanganate or any other oxidising agent?

Ans. Mustard contains turmeric which gives it a beautiful colour, and also acts like a dye. Because of this, it can be very difficult to remove the stain. Some chemicals, like alcohol, hydrogen peroxide, vinegar and perchloroethylene can be used for removing stains at home. There are several oxidative discharge agents used in the textile industry like sodium hypochlorite, sodium chlorite and potassium permanganate, etc. which are not recommended at all for use at home.

Potassium permanganate is a strong oxidising agent when dissolved in water.



The manganese oxide (MnO_2) left behind by potassium permanganate reactions is deep brown in colour and this reagent is used industrially to discharge indigo-dyed denims, but it is extremely poisonous and also becomes dangerously explosive if its solution is left to dry up.

Apart from these, ammonia (NH_3) is also not used for removing the stains from clothes. It reacts with turmeric (the ingredient in mustard) that makes it yellow and hence, making the stain permanent.

Q2. Saccharin (550 times sweeter than sugar) is a well known sweetening agent and a sugar substitute in foods and beverages. On the other hand, chloramine-T is an antiseptic and a mild disinfectant used in hospitals, laboratories

where control of pathogens is required. How can these two compounds be obtained from a single organic compound?

Ans. Saccharin and chloramine-T, both of these compounds can be prepared from methyl cyclohexane as follows :

Catalytic dehydrogenation of methyl cyclohexane gives toluene which on treatment with chlorosulphonic acid yields a mixture of *ortho* and *para*-toluenesulphonyl chloride.

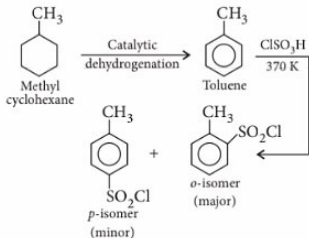

Ortho-isomer reacts with ammonia and potassium permanganate to give saccharin.

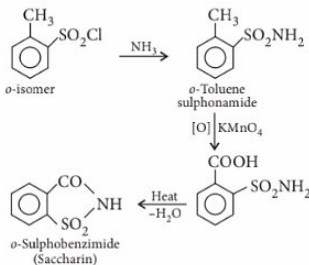

Para-isomer reacts with ammonia and NaOCl/NaOH to give chloramine-T.

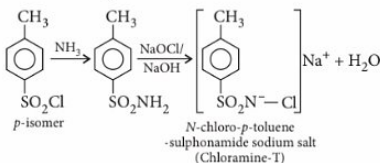

Now, savings of up to ₹920* with MTG's subscription plans!

**On cover price of ₹40/-*

Our new offers are here!

Pick the combo best suited for your needs. Fill-in the Subscription Form at the bottom and mail it to us today. If in a rush, log on to www.mtg.in now to subscribe online.

**For JEE
(Main &
Advanced),
NEET and
BOARDS**

About MTG's Magazines

Perfect for students who like to prepare at a steady pace, MTG's magazines (**Physics For You, Chemistry Today, Mathematics Today & Biology Today**) ensure you practice bit by bit, month by month, to build all-round command over key subjects. Did you know these magazines are the only source for solved test papers of all national and state level engineering and medical college entrance exams?



Over 1.2 Cr readers. Since 1982.

- Practice steadily, paced month by month, with very-similar & model test papers
- Self-assessment tests for you to evaluate your readiness and confidence for the big exams
- Content put together by a team comprising experts and members from MTG's well-experienced Editorial Board
- Stay up-to-date with important information such as examination dates, trends & changes in syllabi
- All-round skill enhancement – confidence-building exercises, new studying techniques, time management, even advice from past JEE/NEET/ AIIMS toppers
- Bonus: Exposure to competition at a global level, with questions from International Olympiads & Contests

Lifetime Subscription Plan for teachers, and special schemes and offers available for libraries and coaching institutes.
SMS MTG to 8800255334 to learn more.

SUBSCRIPTION FORM

Confirm your choice by placing tick-marks in relevant boxes.

Plan 1: Individual magazines P, C, M, B	<input type="checkbox"/> Physics	27 months	15 months	9 months	Name: _____ _____
	<input type="checkbox"/> Chemistry <input type="checkbox"/> Mathematics <input type="checkbox"/> Biology	<input type="checkbox"/> ₹850 (save ₹ 230)	<input type="checkbox"/> ₹500 (save ₹ 100)	<input type="checkbox"/> ₹300 (save ₹ 60)	
Plan 2: Combo of 3	<input type="checkbox"/> PCM	<input type="checkbox"/> ₹2500 (save ₹ 740)	<input type="checkbox"/> ₹1400 (save ₹ 400)	<input type="checkbox"/> ₹900 (save ₹ 180)	Pin Code <input type="text"/> <input type="text"/> <input type="text"/> <input type="text"/> <input type="text"/> <input type="text"/>
	<input type="checkbox"/> PCB	<input type="checkbox"/> ₹3400 (save ₹ 920)	<input type="checkbox"/> ₹1900 (save ₹ 500)	<input type="checkbox"/> ₹1200 (save ₹ 240)	
Plan 3: PCMB Combo		<input type="checkbox"/> ₹600	<input type="checkbox"/> ₹450	<input type="checkbox"/> ₹240	Other Phone # 0 <input type="text"/> <input type="text"/> <input type="text"/> <input type="text"/> <input type="text"/> <input type="text"/> <input type="text"/> <input type="text"/> <input type="text"/> <input type="text"/>
Courier Charges <i>Add to your subscription amount for quicker & reliable delivery</i>					Email _____
Recommended by (Optional)	Name of your teacher _____				Enclose Demand Draft favouring MTG Learning Media (P) Ltd , payable at New Delhi. Mail this Subscription Form to Subscription Dept., MTG Learning Media (P) Ltd , Plot 99, Sector 44, Gurugram -122 003 (HR).
Teacher's Mobile #	<input type="text"/> <input type="text"/> <input type="text"/> <input type="text"/> <input type="text"/> <input type="text"/> <input type="text"/> <input type="text"/> <input type="text"/> <input type="text"/>				

Note: Magazines are despatched by Book-Post on 4th of every month (each magazine separately).

E-mail subscription@mtg.in. Visit www.mtg.in to subscribe online. Call (0)1800-110-38673 for more info.

Get digital editions of MTG Magazines on <http://digital.mtg.in/>



INTRODUCING

THE SMART STUDY SYSTEM

100%
CBSE

MTG's 100 Percent Series is based on the most current CBSE guidelines and curriculum

MTG's editorial team knows what it takes to score more in exams - it keeps a close watch on changing examination patterns and has been able to put all ingredients critical to success together in a package aptly titled 100 Percent

100%
SCIENTIFIC

Be it easy-to-comprehend text, graphics, illustrations or concept maps that complement, understanding theory and concepts is so straightforward with 100 Percent

100%
CONTENT

After each topic, in every chapter, 100 Percent presents students with a variety of Q&A including "Try Yourself", "NCERT Focus", "CBSE Focus" & "Competition Focus"

100%
CHECKS

100 Percent goes all out to ensure students are prepared for a diverse set of future challenges through a variety of exam drills and practice papers, even Viva Voce Q&A for lab-based experiments

100%
PRACTICE

For
CBSE
Classes
9 & 10



100 PERCENT for Science & Mathematics



Scan to buy online
(QR code reader required)

Visit bit.ly/100percent to buy online or to know more. Or email info@mtg.in now.

NEET
2015

More than
70%
same or
similar MCQs

NEET
2016

More than
60%
same or
similar MCQs

NEET
2017

More than
60%
same or
similar MCQs

NEET
2018

More than
80%
same or
similar MCQs

NEET
2019

More than
80%
same or
similar MCQs

Trust MTG for getting it right, year after year

Over the last 5 years, MTG has averaged a hit rate of 70% when it comes to curating the right content for your NEET preparation. Which means approx. 3 out of 4 questions in NEET were either exactly the same as, or similar to, questions in MTG's NEET books. The credit for this mind-blowing feat goes to MTG's skilled and experienced editorial team which painstakingly goes through volumes of NCERT subject matter that forms the basis for NEET, to create superior and relevant study material that has a high chance of success for its users. Proof lies in the pudding, right!

MTG's best-selling NEET books include

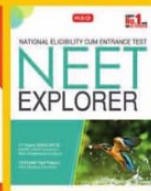
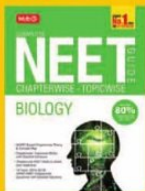
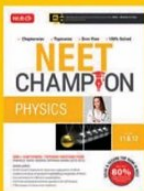
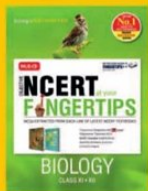

Scan to buy on mtg.in

To find out which MTG NEET book is best-suited to your needs, call our NEET helpline toll-free at **1800-10-38673** today. Or email info@mtg.in now. Visit bit.ly/mtg-need to buy online.

mtg



Scan to buy on Amazon.in